



iso 9001 - Cert. N° 0633



ATEX
CERTIFIED

HPD - HPE - HPEDS

Pompe a doppio supporto a uno o due stadi a norme API 610 - 10^a edizione
One and two stage between-bearings pumps according to API 610 - 10th edition Norms



2950 rpm

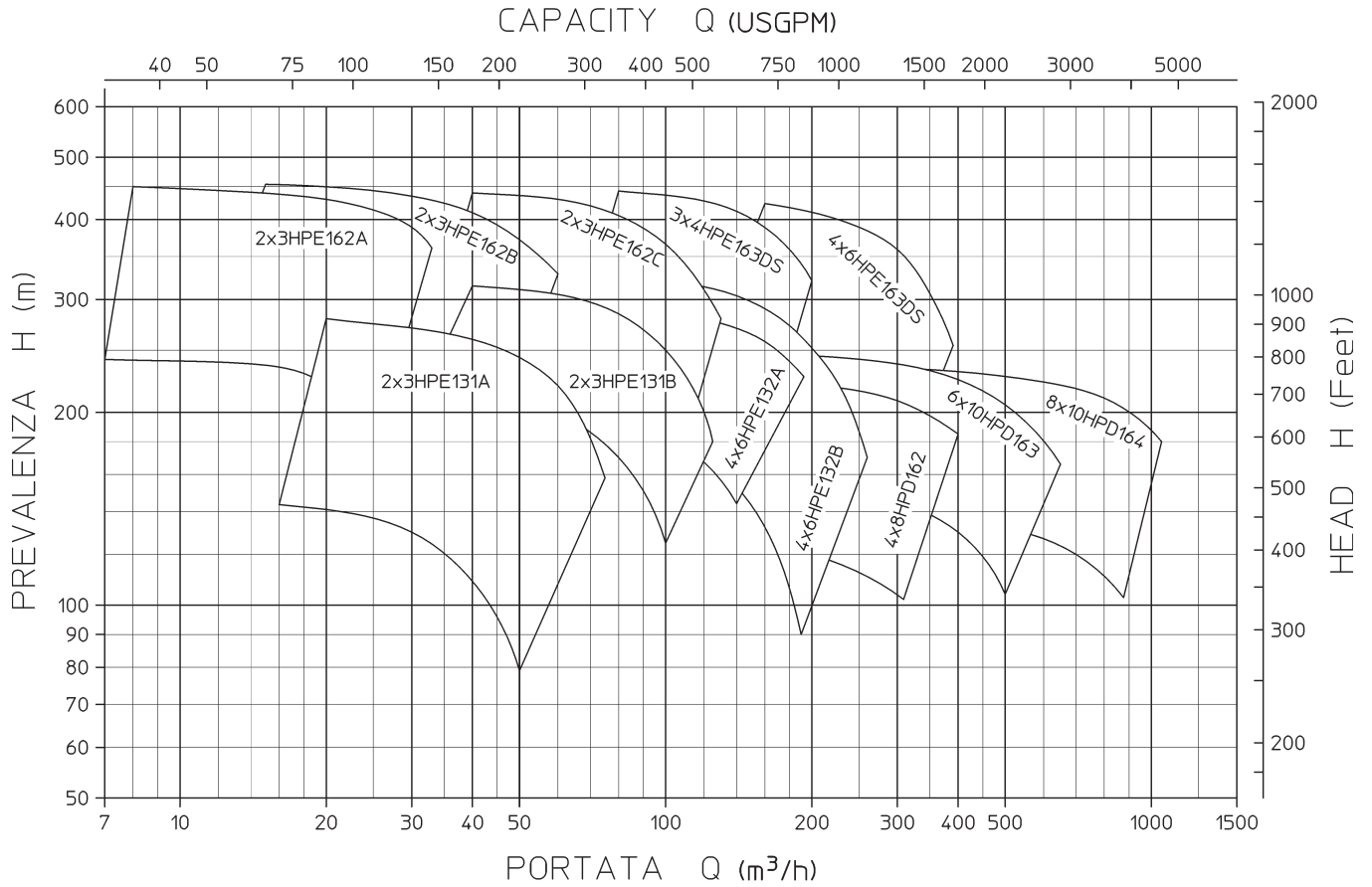

1475 rpm

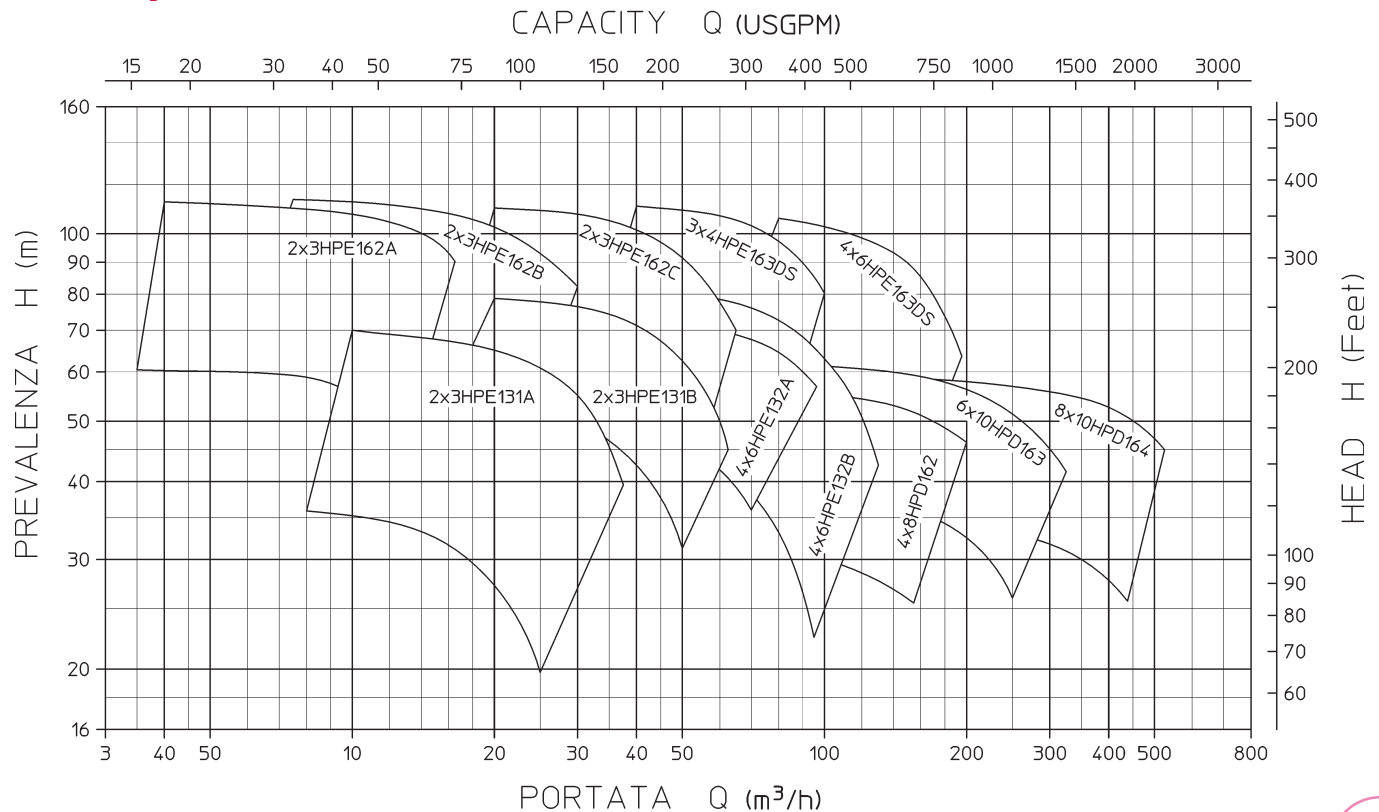

Le pompe HPE - HPEDS e HPD sono certificate ATEX su richiesta

3540 rpm

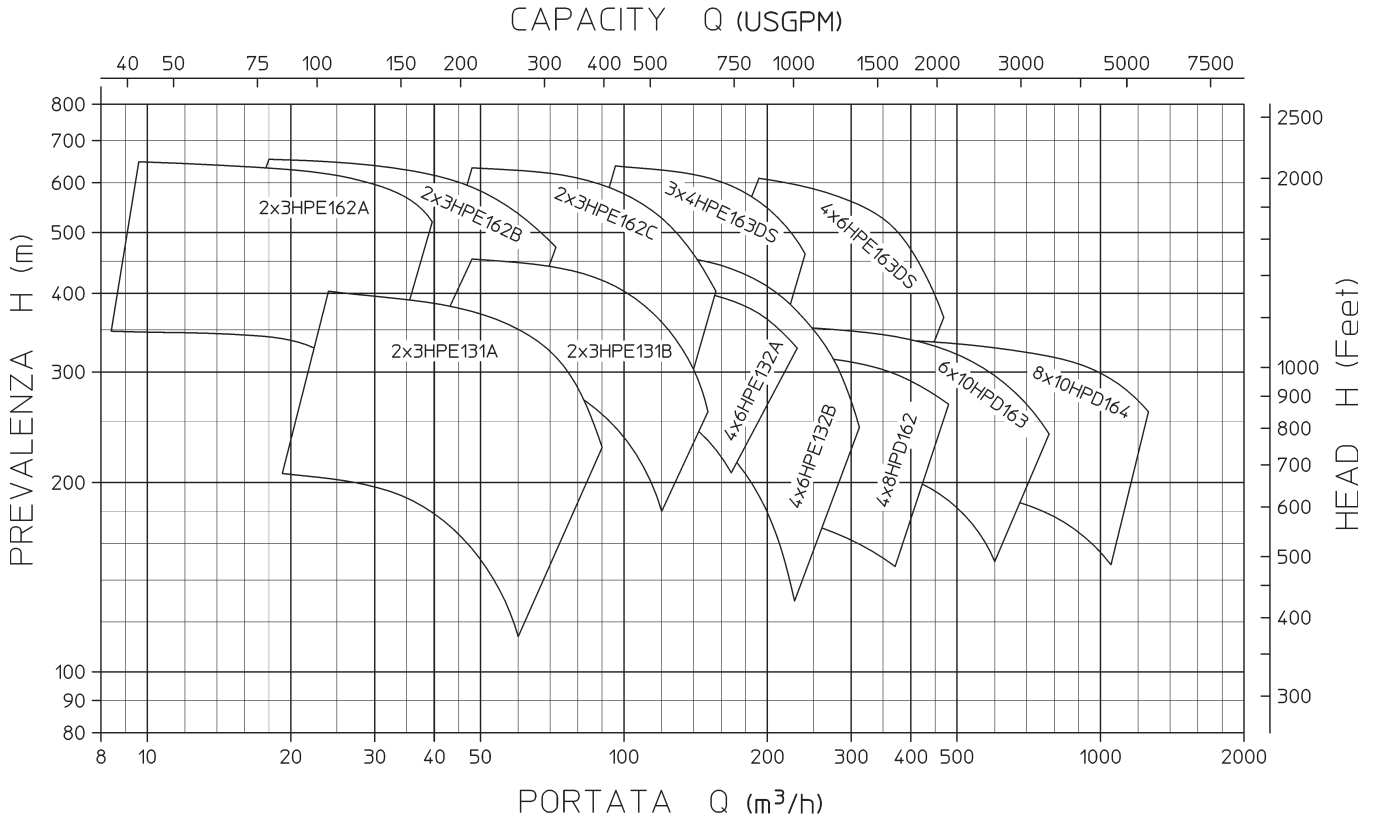

1770 rpm

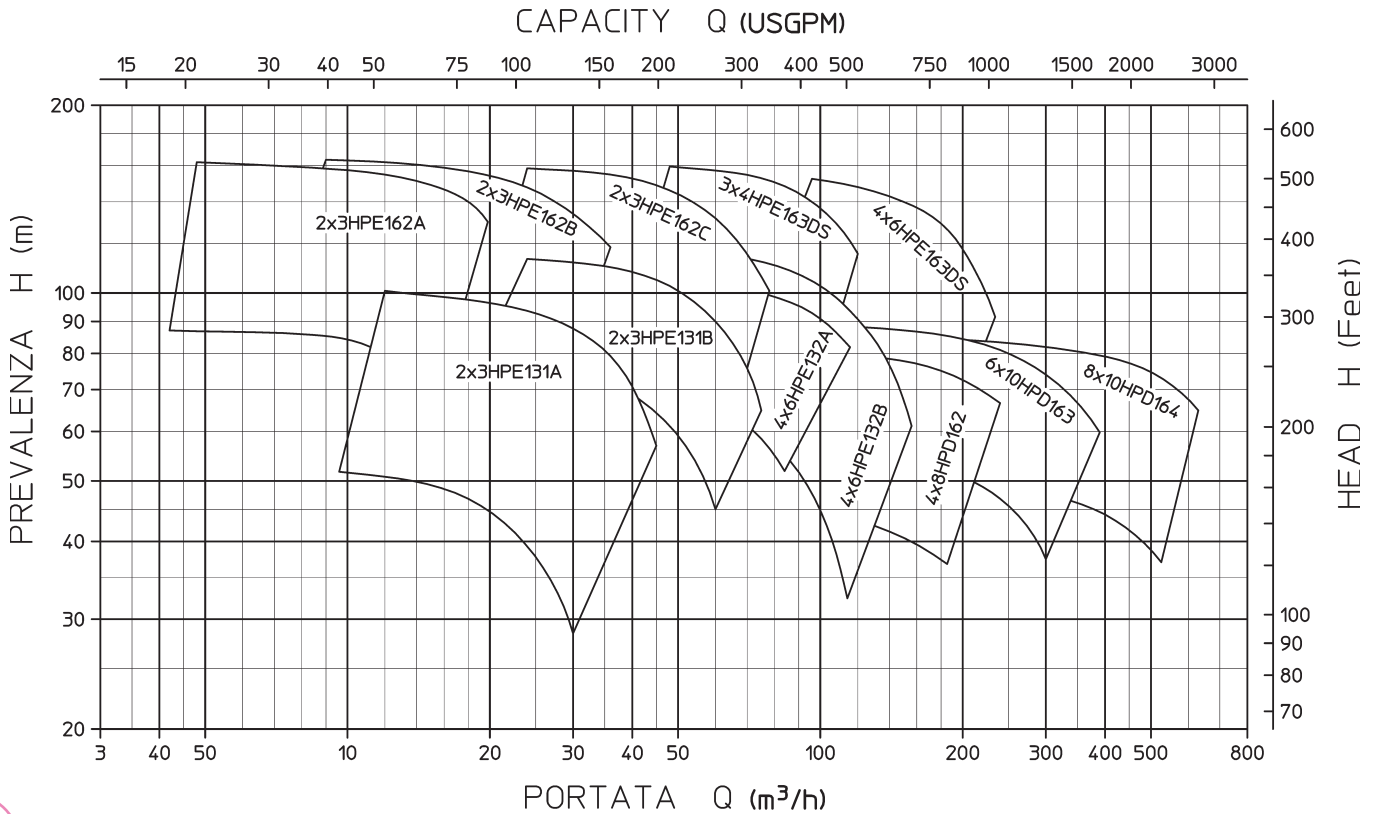

... according
4/9/REG B. b ii
stored



HPE - HPEDS and HPD pumps are **ATEX** certified upon request.

Informacje techniczne i handlowe tel: + 48 41 2429672; fax: + 48 41 2434011

Pompe a due stadi con la prima girante a singola aspirazione

HPE

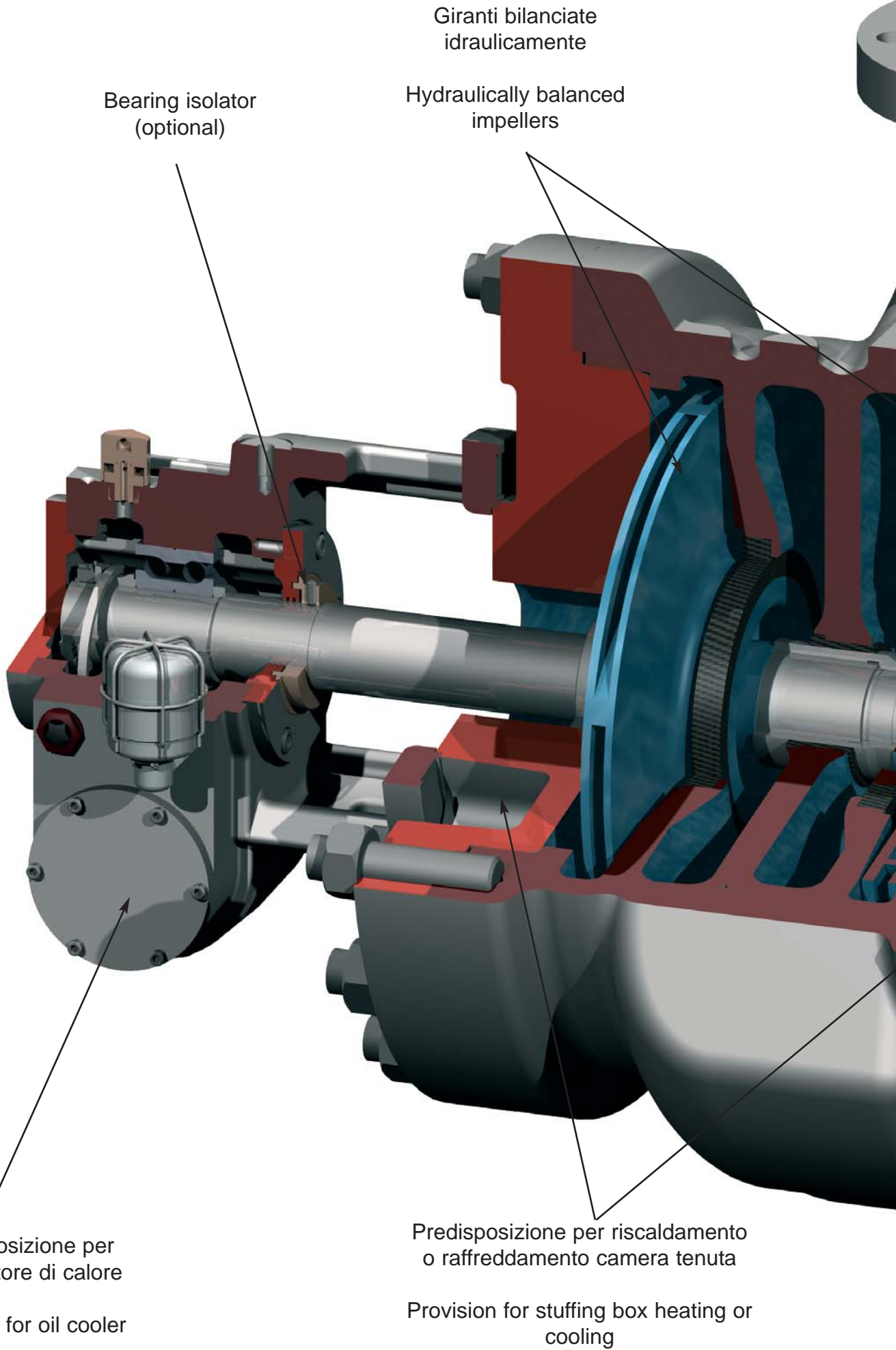

Bearing isolator
(optional)

Giranti bilanciate
idraulicamente

Hydraulically balanced
impellers

Predisposizione per
scambiatore di calore

Provision for oil cooler

Predisposizione per riscaldamento
o raffreddamento camera tenuta

Provision for stuffing box heating or
cooling

Two stage pumps with single suction first stage impeller

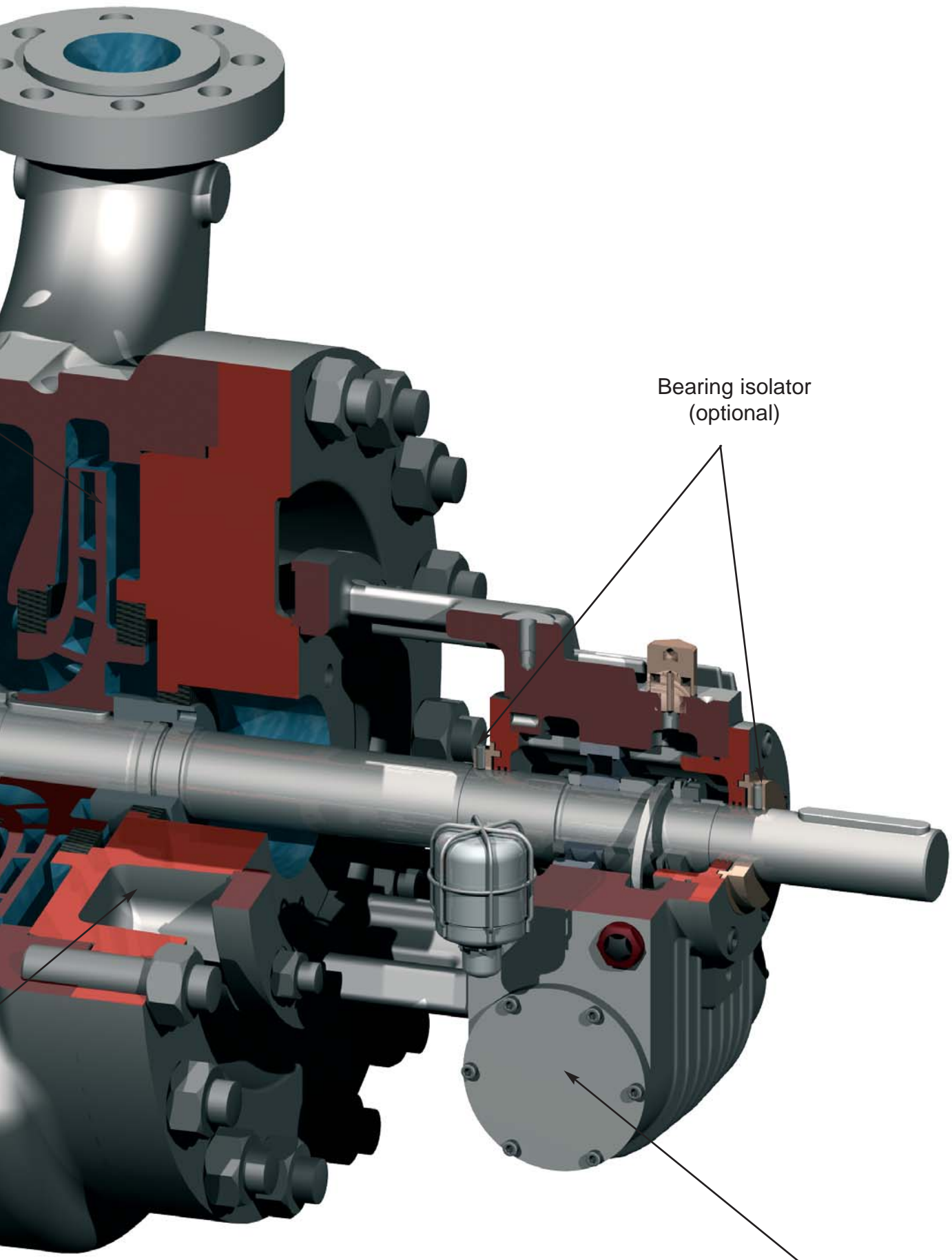

Bearing isolator
(optional)

Predisposizione per
scambiatore di calore

Provision for oil cooler

Pompe a due stadi con la prima girante a doppia aspirazione

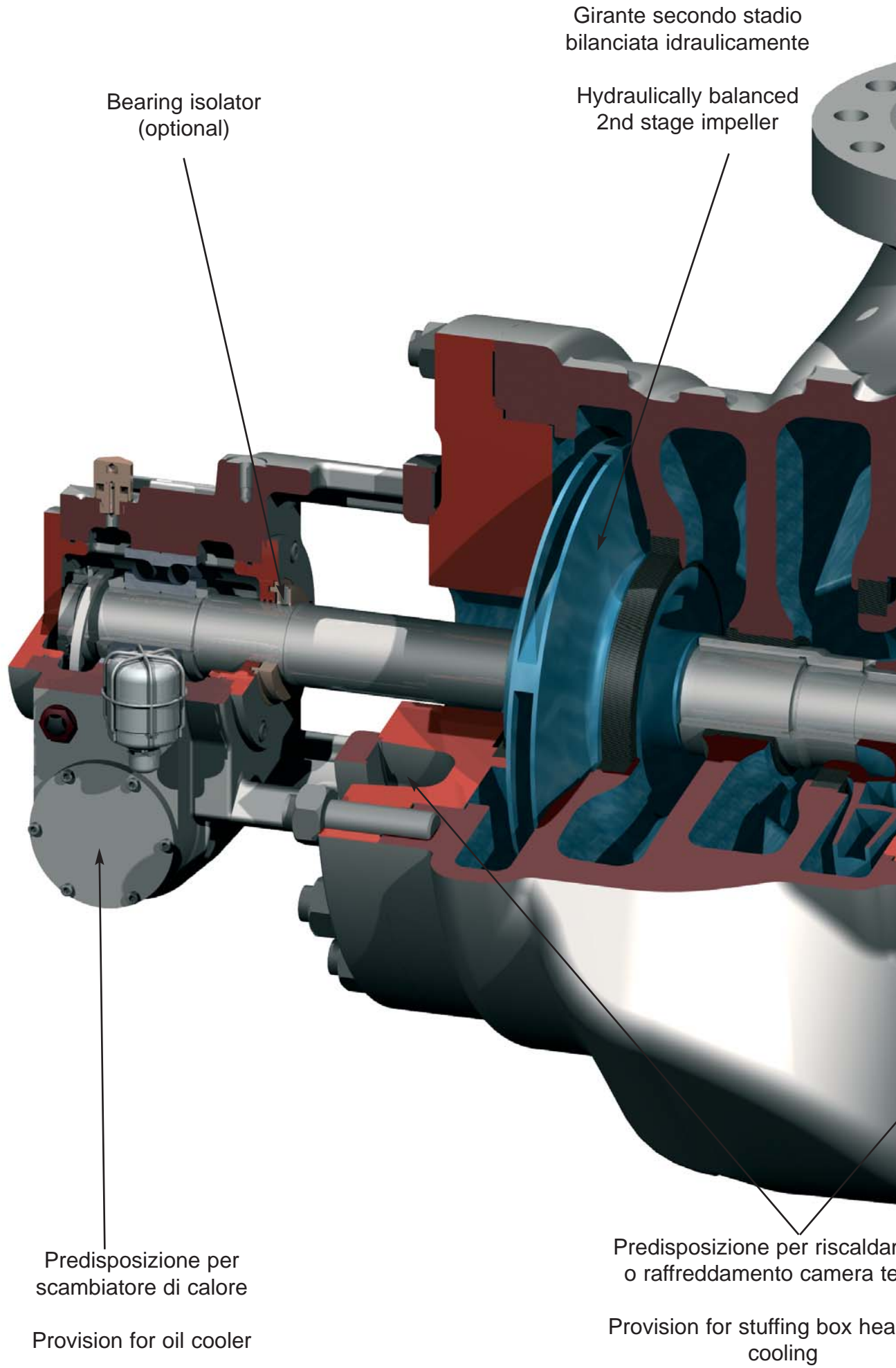

Bearing isolator (optional)

Girante secondo stadio bilanciata idraulicamente

Hydraulically balanced 2nd stage impeller

Predisposizione per scambiatore di calore

Provision for oil cooler

Predisposizione per riscaldamento o raffreddamento camera te

Provision for stuffing box heating cooling

Two stage pumps with double suction first stage impeller

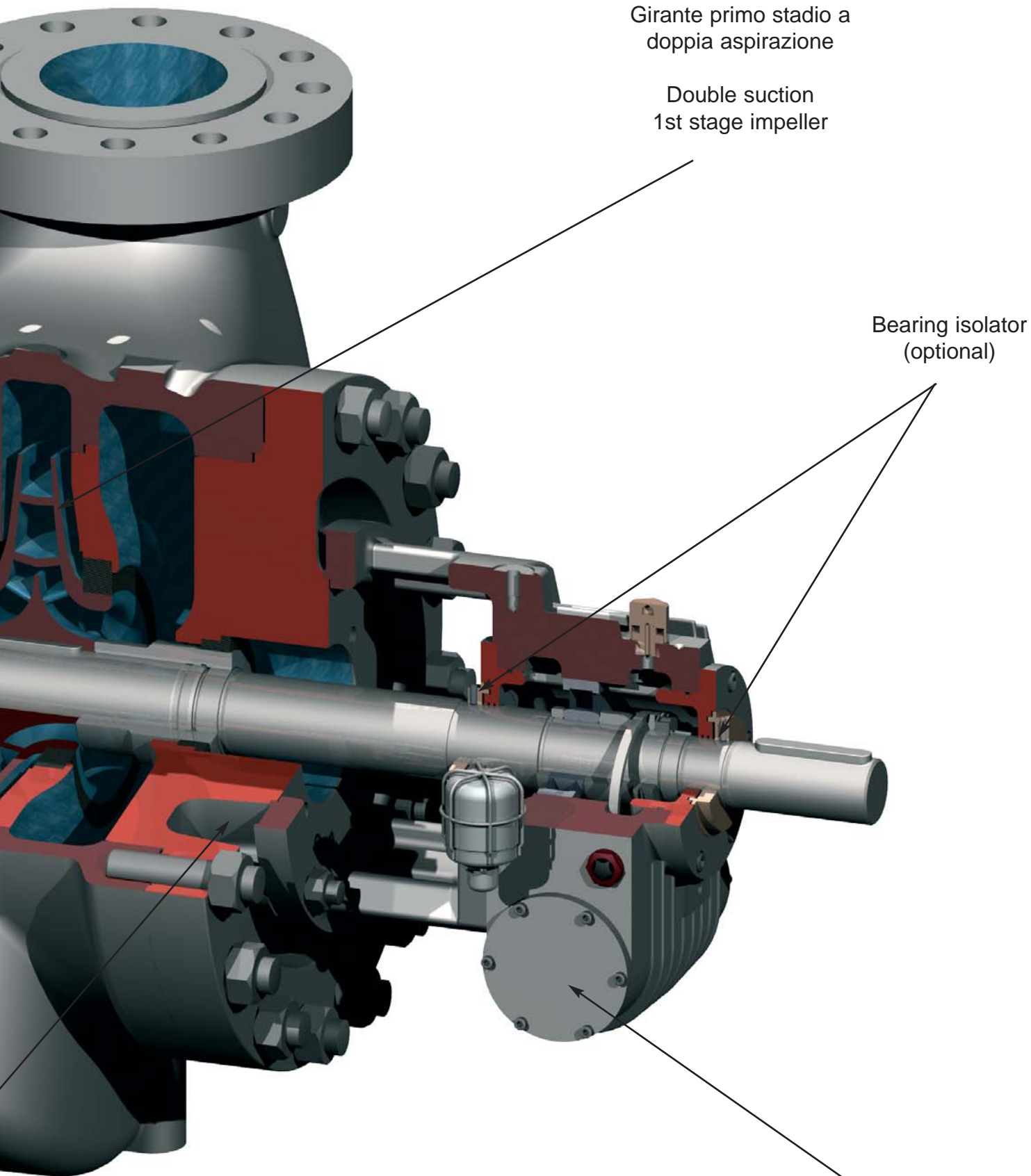

Girante primo stadio a
doppia aspirazione

Double suction
1st stage impeller

Bearing isolator
(optional)

Predisposizione per
scambiatore di calore

Provision for oil cooler

mento
nuta
ting or

Pompe monostadio con girante a doppia aspirazione

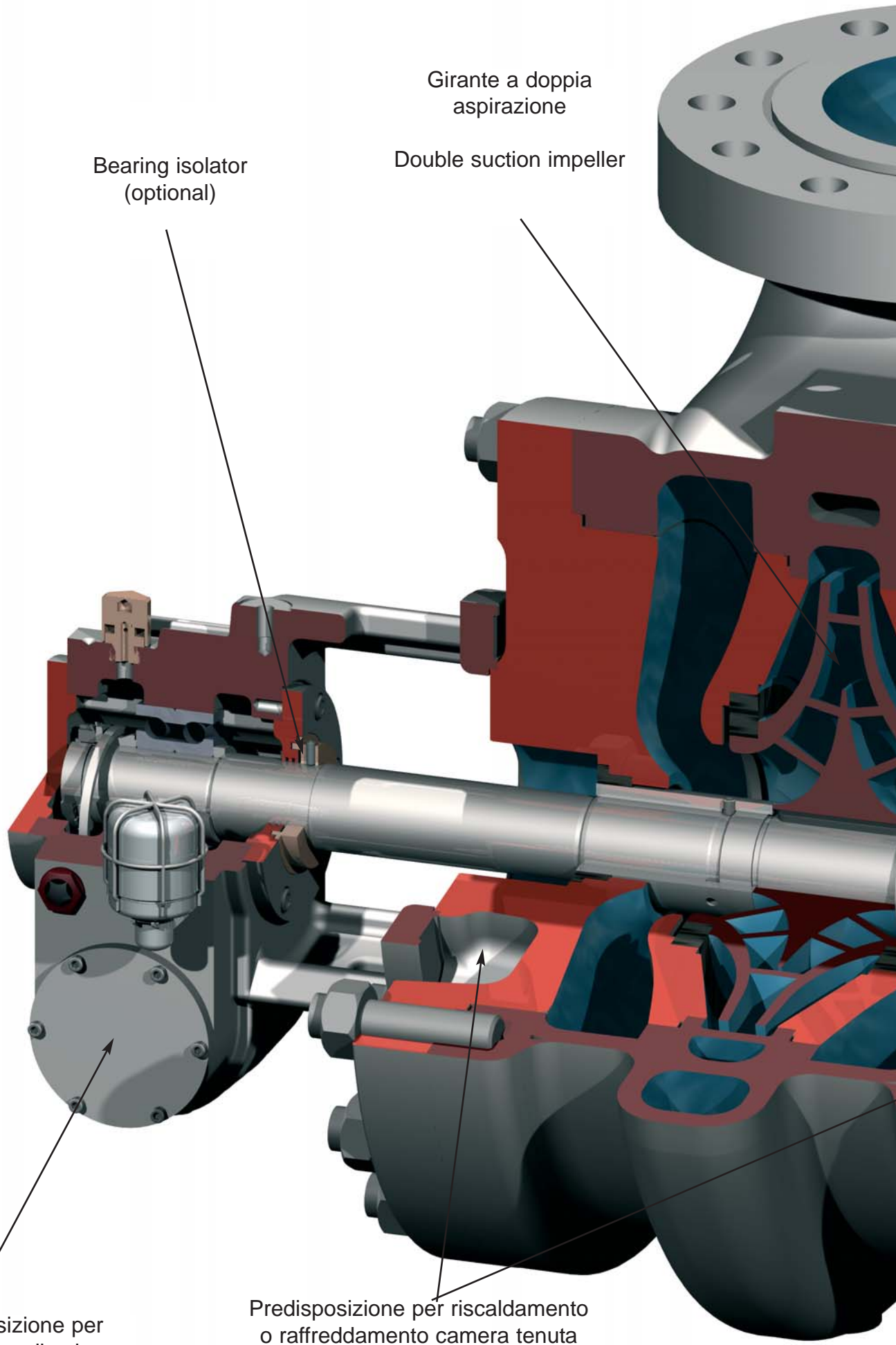

Bearing isolator
(optional)

Girante a doppia
aspirazione

Double suction impeller

Predisposizione per
scambiatore di calore

Predisposizione per riscaldamento
o raffreddamento camera tenuta

Provision for oil cooler

Provision for stuffing box heating or
cooling

Single stage double suction pumps

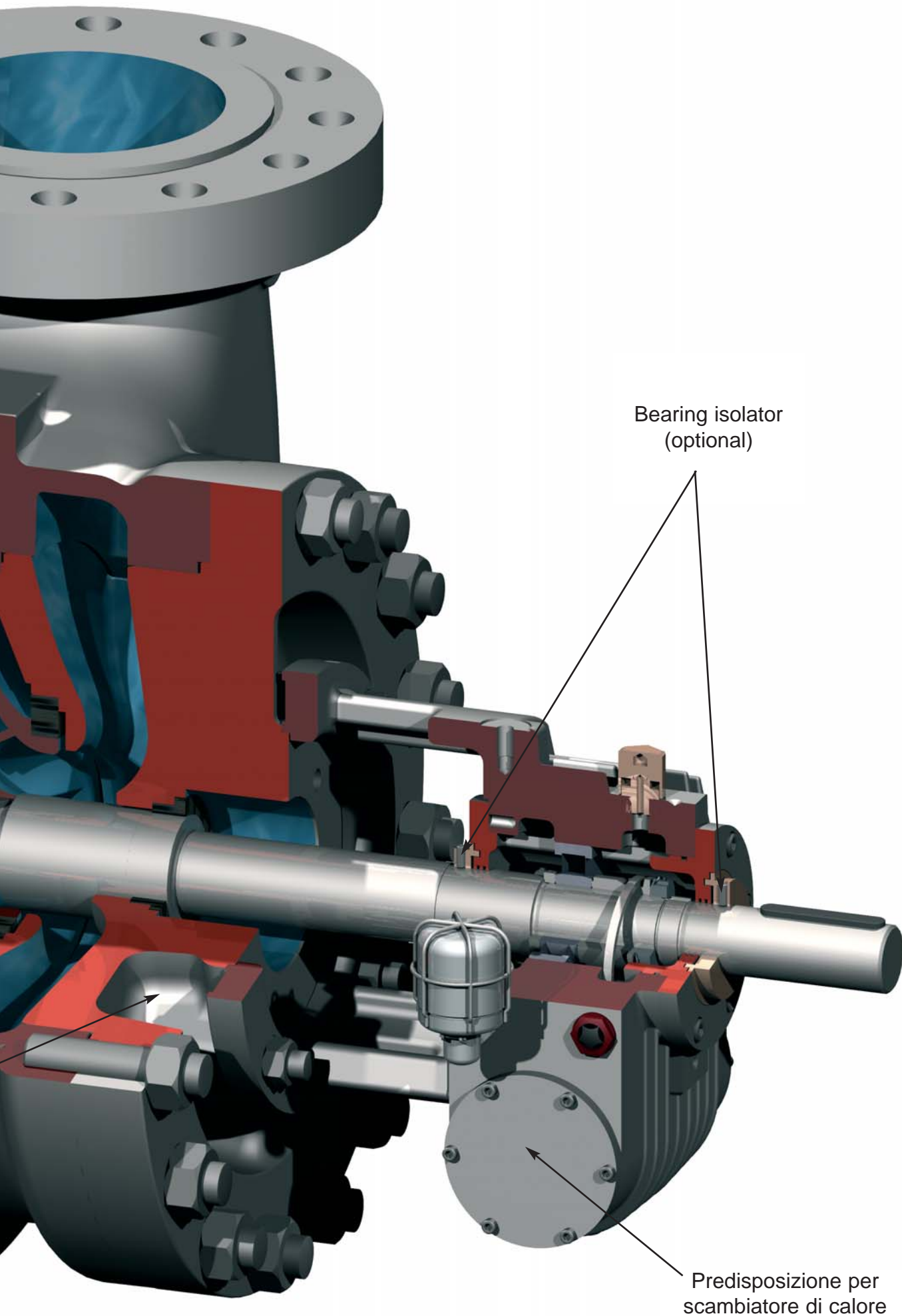

Bearing isolator
(optional)

Predisposizione per
scambiatore di calore

Provision for oil cooler

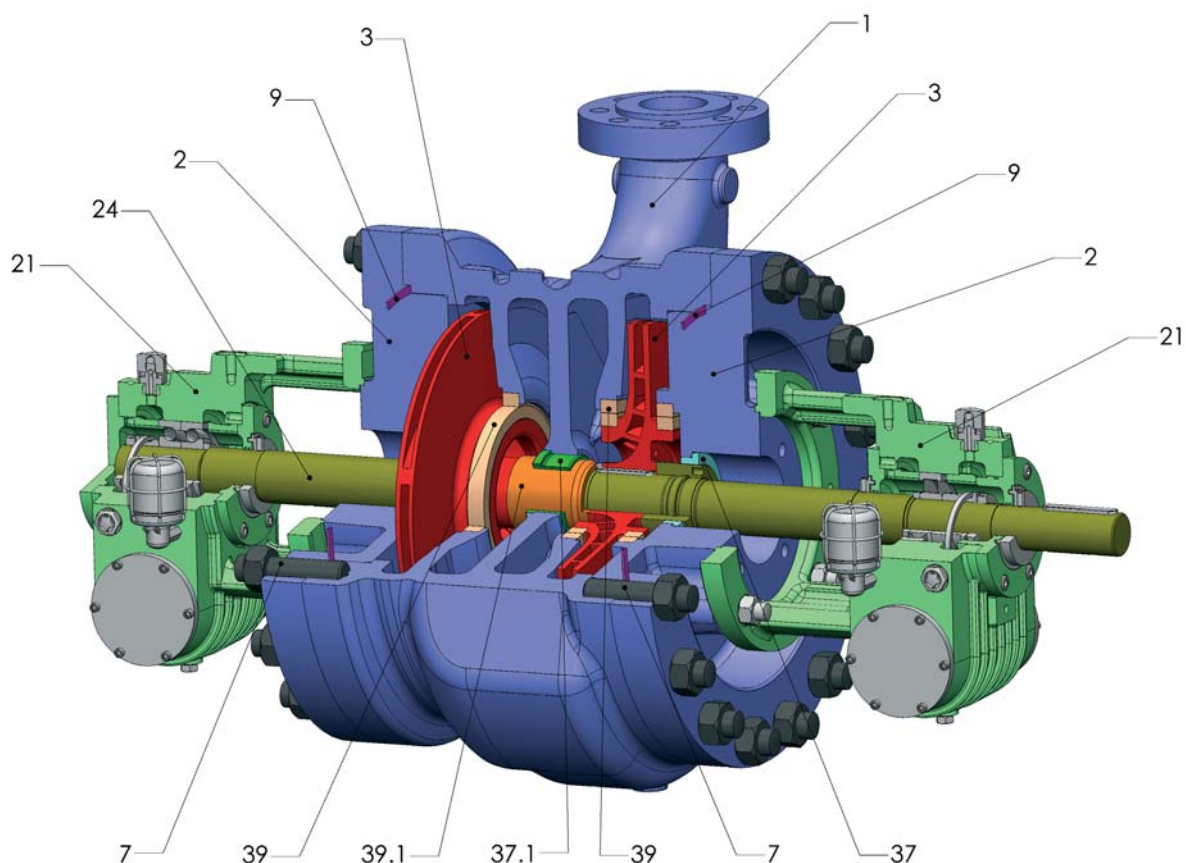

Nomenclatura & Materiali di costruzione

Part List & Materials of Construction

ITEM	Description Descrizione	Materials of construction according to API610 Xed. Table H.1 Materiali di costruzione secondo API 610 Xed. Tabella H.1									
		I-1	S-4	S-5	S-6	S-8	C-6	A-7	A-8	D-1	D-2
1	Pressure casing Corpo pompa	A278 Cl.300	A216 Gr.WCB				A487 CA6NM	A351 CF3	A351 CF3M	A890 Gr.1B	A890 Gr.5A
2	Cover Scudo										
3	Impeller Girante	A278 Cl.250	A216 Gr.WCB	A487 CA6NM	A351 CF3M	A487 CA6NM	A351 CF3	A351 CF3M	A890 Gr.1B	A890 Gr.5A	
7	Case and gland studs Prigionieri corpo pompa	A193 Gr.B7									
9	Case gasket Guarnizione corpo	AISI 316 + Graphite (Grafite)									
21	Bearing housing Supporto	A216 Gr.WCB									
24	Shaft Albero	A434 Cl.BB				A276 Ty.316L	A276 Ty.410	A276 Ty.316L	A276 S31803	A276 S32760	
37	Throat bushing Bussola di fondo	A278 Cl.250	A276 Ty.420 Hardened		A276 Ty.316L	A276 Ty.420 Hardened	A276 Ty.316L	A276 S31803	A276 S32760		
37.1	Interstage bushing Bussola interstadio	A278 Cl.250	A276 Ty.420 Hardened		A276 Ty.316L HardFaced	A276 Ty.420 Hardened	A276 Ty.316L Hard faced	A276 S31803 Hard faced	A276 S32760 Hard faced		
39	Wear ring Anelli di usura	A278 Cl.250	A276 Ty.420 Hardened		A276 Ty.316L Hard faced	A276 Ty.420 Hardened	A276 Ty.316L Hard faced	A276 S31803 Hard faced	A276 S32760 Hard faced		
39.1	Interstage sleeve Camicia interstadio	A278 Cl.250	A276 Ty.420 Hardened		A276 Ty.316L HardFaced	A276 Ty.420 Hardened	A276 Ty.316L Hard faced	A276 S31803 Hard faced	A276 S32760 Hard faced		

Descrizione

Pompe centrifughe di processo a doppio supporto, singola o doppia girante, progettate e costruite in accordo alla normativa API 610, 10a edizione.

Le HPD sono pompe monostadio con girante a doppia aspirazione e corpo a divisione radiale.

Le HPE sono pompe a due stadi con la prima girante a singolo o doppio imbocco, secondo la portata di progetto.

Entrambe le linee di pompe corrispondono alla forma costruttiva BB2 prevista dalla normativa di riferimento.

La costruzione compatta ed il generoso dimensionamento dei singoli componenti e dell'assieme le rendono idonee ai servizi più gravosi: in queste pompe, le spinte assiali sono intrinsecamente bilanciate in modo da minimizzare il carico su albero e cuscinetti reggispinta.

La cura nella progettazione, nella costruzione e nella bilanciatura dinamica delle parti rotanti garantiscono affidabilità e livelli di vibrazioni particolarmente contenuti.

Per i servizi a temperature elevate è previsto il raffreddamento dei cuscinetti mediante uno scambiatore di calore realizzato in acciaio inossidabile e progettato in modo da poter essere facilmente inserito e rimosso per manutenzione dal supporto cuscinetti, senza necessità di smontare il supporto stesso. In alternativa, è previsto il raffreddamento ad aria su entrambi i lati della pompa mediante ventole calettate sull'asse, anch'esse appositamente disegnate e realizzate in alluminio pressofuso. Le pompe HPE e HPD possono essere realizzate in tutte le combinazioni di materiali previste dalla normativa di riferimento ed in materiali speciali per servizi su liquidi aggressivi.

Description

Single and two stage between bearing process pumps designed and manufactured according to API 610, 10th ed.

HPD are single stage double suction radially split casing pumps.

HPE are two stage pumps with either single or double suction first stage impeller, depending on the design capacity.

Both series of pumps correspond to type BB2 as described in the reference standard.

Compact design and generously sized components make these pumps suitable for the most critical applications: in the HPD and HPE pump series, the axial thrust is intrinsically balanced in order to minimize shaft and bearings loads.

Care in design and manufacturing as well as dynamic balancing of rotating parts will grant equipment reliability and smooth operation with low residual vibrations.

For high temperature duties, cooling of the bearings can be obtained by means of specifically designed stainless steel integral coolers which can easily be installed and removed for maintenance purposes without dismounting the bearing housing. As an alternative, custom designed, integrally cast aluminium air fans can be fitted on both drive and non drive end.

HPD and HPE pumps can be manufactured in all the materials combination foreseen by the reference standard and in special alloys for chemically aggressive services.



Finder Pompe S.p.A.
23807 MERATE (Lc) - ITALY
Via Bergamo, 65
Tel. +39 039 9982.1
Fax +39 039 599267
e-mail: finder@finderpompe.com
Internet: www.finderpompe.com

