

# MCG3 series Lift / Turntable

## TRIPLE-GUIDE CYLINDER



### Features:

- Three guide rods equally spaced in the aluminum body provide more space saving and eliminate the directionality of the unbalanced load.
- Conveyor line's productivity increases.
- By connecting with the Rotary actuator, can be used as a Automatic turn lifter.
- Standard with magnet.

### Specification:

Model	MCG3	
Model (Stop type view)	 ( Lift type )      ( Turntable type )	
Acting type	Double acting	
Tube I.D.(mm)	63	80
Port size Rc(PT)	1/4	3/8
Standard stroke	30, 50, 75, 100 mm	
Medium	Air	
Operating pressure range	1~9.9 kgf/cm <sup>2</sup>	
Proof pressure	15 kgf/cm <sup>2</sup>	
Ambient temperature	- 5~ + 60°C (No freezing)	
Lubrication	Not required	
Cushion	With rubber cushion pad	
Sensor switch	RCB,RCE,RCE1	

### Order example:

**MCG3 — 63 — 50 — D — BSP**

MODEL

STROKE\*

TUBE I.D.

63  
80: only for life type

APPLICATION / TYPE OF BEARING

Code	Purpose / Type of bearing
<b>D</b>	Circle table lift / Slide bearing
<b>B</b>	Circle table lift / Linear bush bearing
<b>D90</b>	Turntable / Angle 90° / Slide bearing
<b>B90</b>	Turntable / Angle 90° / Linear bush bearing
<b>D180</b>	Turntable / Angle 180° / Slide bearing
<b>B180</b>	Turntable / Angle 180° / Linear bush bearing
<b>QD</b>	Quad table lift / Slide bearing
<b>QB</b>	Quad table lift / Linear bush bearing

PORT THREAD  
Blank: PT thread  
**BSP**: BSP thread  
**NPT**: NPT thread

\*Stroke out of specification is also available.

## TRIPLE-GUIDE CYLINDER

**Allowable eccentric load :**  
(at supply pressure 0.5MPa)

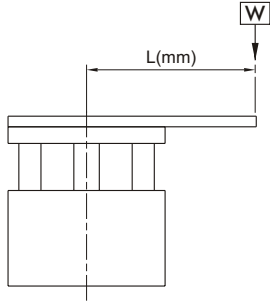

Shows the dynamic allowable value at L(mm) eccentricity from the center of the guide rod.

MCG3-D/D90/D180

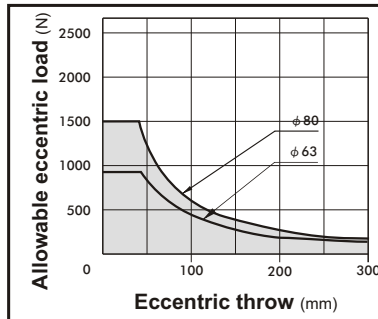

MCG3-B/B90/B180

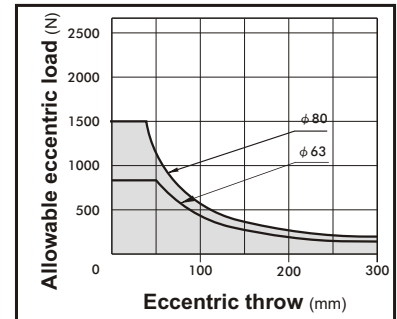

**Allowable rotating torque :**

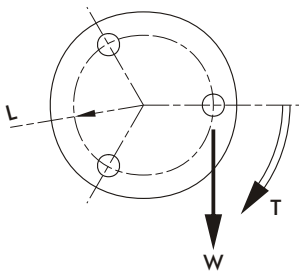

Shows the dynamic allowable value, when actuating the cylinder with a rotating torque T at the guide rods' top.

Tube I.D.	Bearing type	Stroke (mm)		
		30	50	100
$\phi 63$	Slide bearing	13.2	12.7	7.6
	Linear bush bearing	13.5	12.7	8.8

**Anti-roll accuracy :**

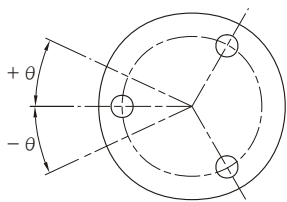

The values are the deflection angle against the piston rod.

Tube I.D.	Bearing type	Anti-roll accuracy
		$\theta$
$\phi 63$	Slide bearing	$\pm 0.07^\circ$
	Linear bush bearing	$\pm 0.03^\circ$

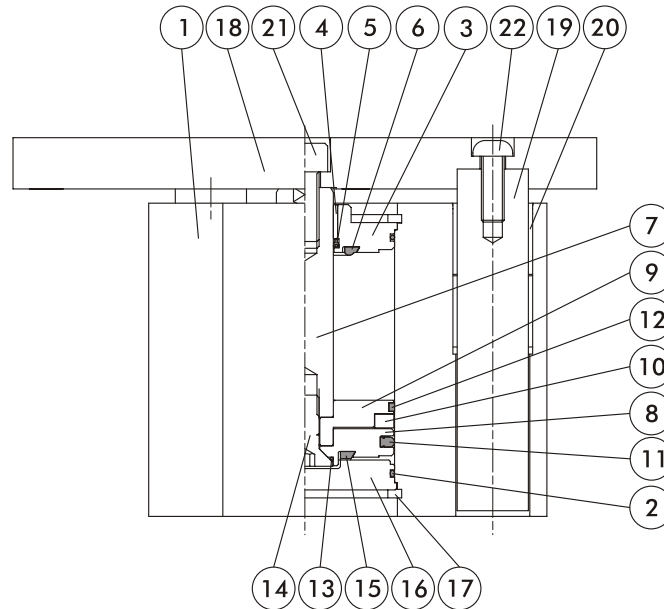

### Material

No.	Part name	Material
1	Body	Aluminum alloy
2	Cover ring	NBR
3	Rod cover	Aluminum alloy
4	Rod bush	Copper
5	Rod packing	NBR
6	Rod cushion	NBR
7	Piston rod	Medium carbon steel
8	Piston	Aluminum alloy
9	Piston for magnet ring	Aluminum alloy
10	Magnet ring	Magnet material
11	Piston packing	NBR
12	Wear ring	Teflon
13	Piston gasket	NBR
14	Screw	Carbon steel
15	Head cushion	NBR
16	End cover	Aluminum alloy
17	Snap ring	Spring steel
18	Plate	Carbon steel
19	Guide rod	Medium carbon steel
20	Guide rod bush	Copper
21	Screw for piston rod	Carbon steel
22	Screw for guide rod	Carbon steel

# MCG3 Lift / Turntable $\phi 63, \phi 80$

## TRIPLE-GUIDE CYLINDER

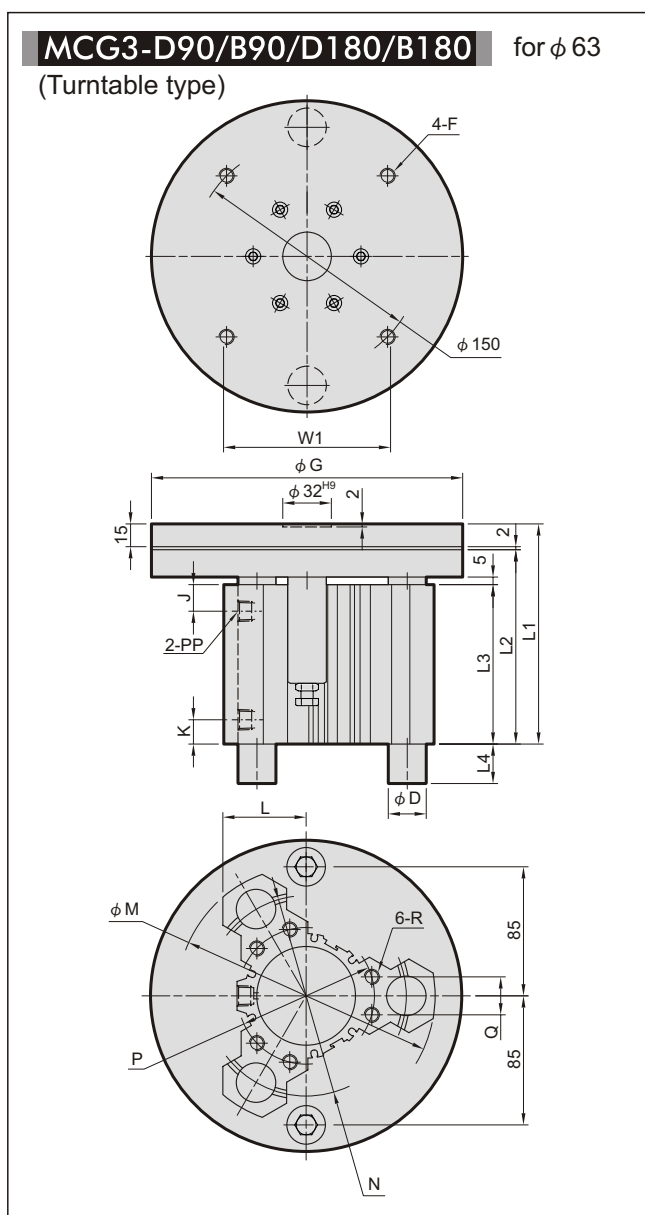
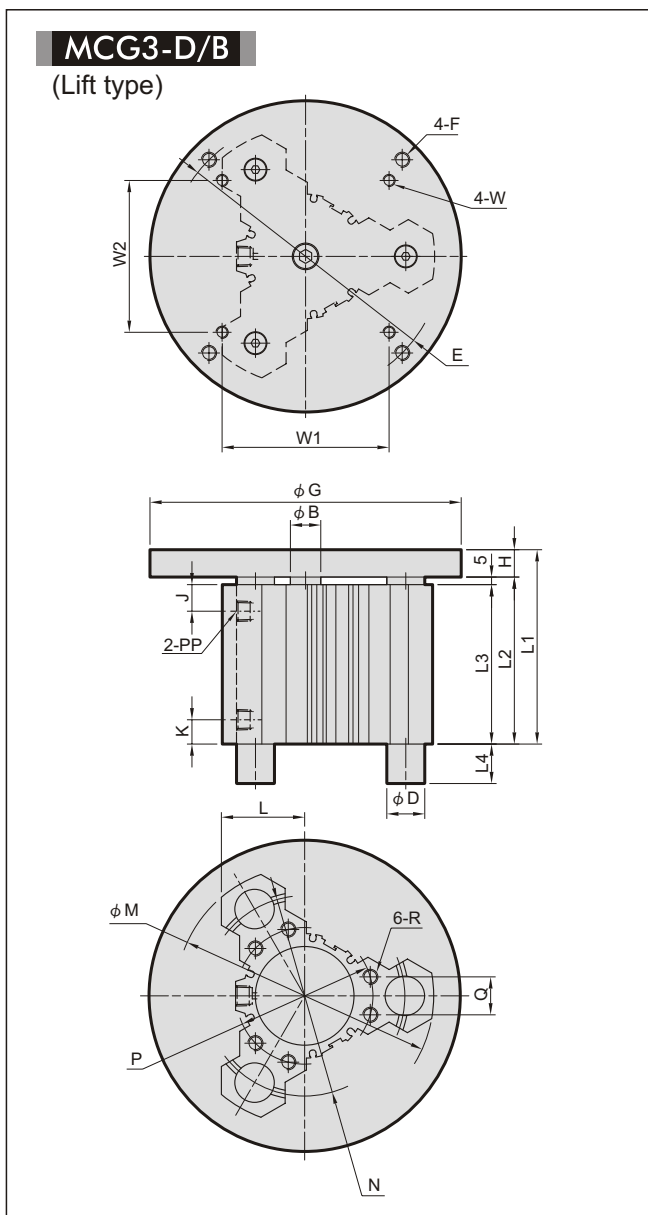

### MCG3-D/B

Code Tube I.D.	B	E	F	G	H	J	K	L	M	N	P	PP	Q	R	W	W1	W2
63	20	P.C.D180	M10×1.5	205	18	17.5	16	54.8	170	P.C.D132	P.C.D90	PT1/4	25	M10×1.5×23depth	M8×1.25	110	100
80	25	P.C.D190	M10×1.5	220	18	22	22	61.2	190	P.C.D150	P.C.D106	PT3/8	32	M10×1.5×23depth	M8×1.25	110	100

Tube I.D.	L1				L2				L3			
	Stroke (mm)											
	30	50	75	100	30	50	75	100	30	50	75	100
63	108	128	153	178	90	110	135	160	85	105	130	155
80	118	138	163	188	100	120	145	170	95	115	140	165

Tube I.D.	L4		$\phi D$	
	MCG3-D	MCG3-B	MCG3-D	MCG3-B
63	0	26	$\phi 25$	$\phi 16$
80	0	25	$\phi 28$	$\phi 20$

### MCG3-D90/B90/D180/B180

Tube I.D.	L1				L2				L3			
	Stroke (mm)											
	30	50	100	30	50	100	30	50	100	30	50	100
63	125	145	195	108	128	178	85	105	155			

Tube I.D.	L4		$\phi D$	
	D90 / D180	B90 / B180	D90 / D180	B90 / B180
63	0	26	$\phi 25$	$\phi 16$

# MCG3 Lift / Installation of sensor switch $\phi 63, \phi 80$

## TRIPLE-GUIDE CYLINDER



### MCG3-QD/QB

(Lift type)

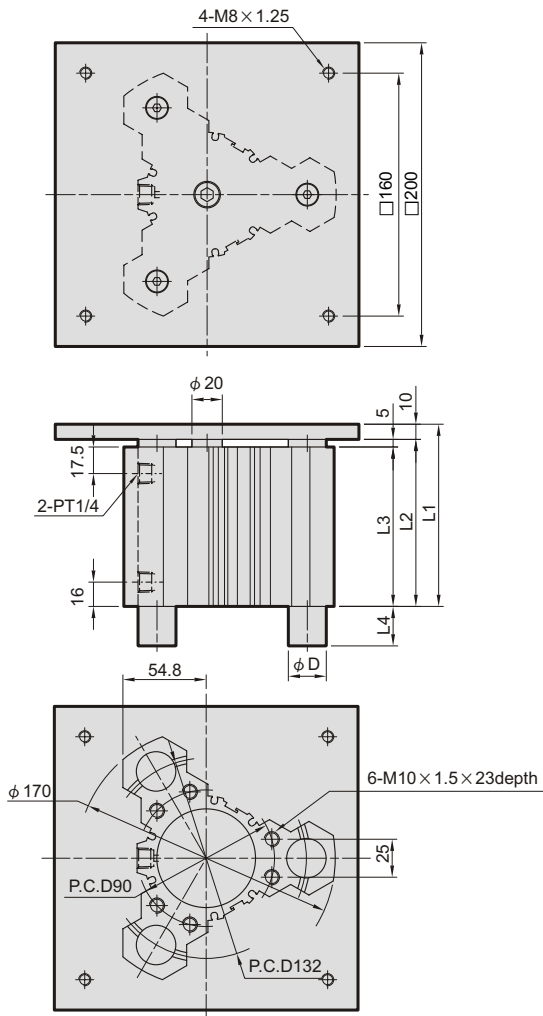

### Installation of sensor switch

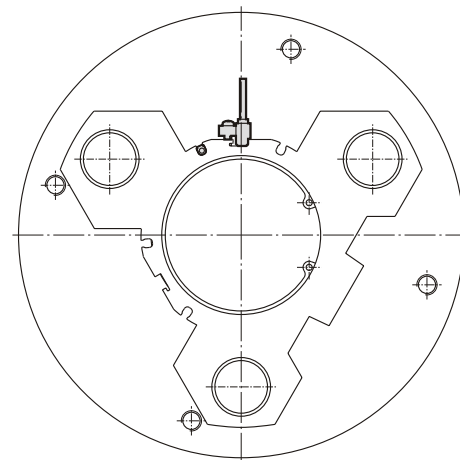
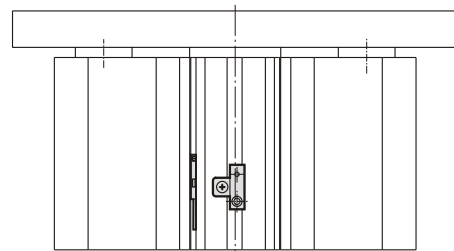
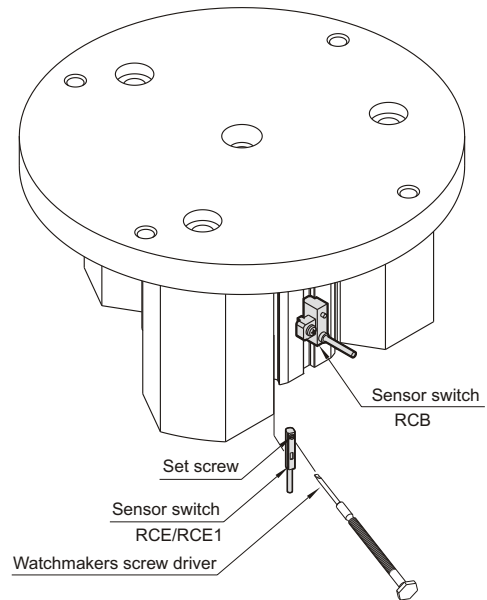

### MCG3-QD/QB

Tube I.D.	Stroke (mm)	L1	L2	L3
63	30	100	90	85
	50	120	110	105
	75	145	135	130
	100	170	160	155

Tube I.D.	L4		$\phi D$	
	MCG3-QD	MCG3-QB	MCG3-QD	MCG3-QB
63	0	26	$\phi 25$	$\phi 16$