

MCJT series

COMPACT CYLINDERS

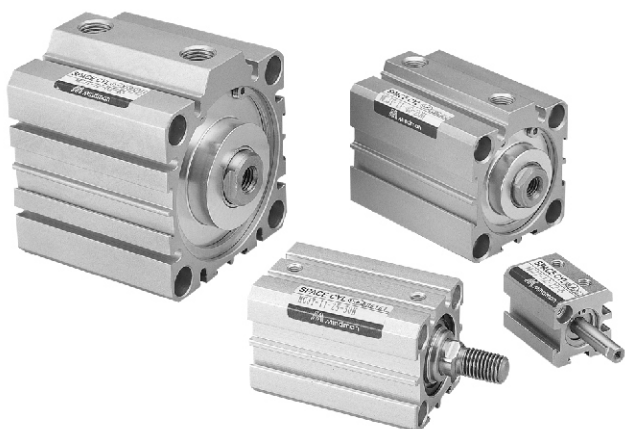

Features:

- Ultra-compact, lightweight, space-saving type.
- Available with a comprehensive selection of bore size (ϕ 12mm~ ϕ 100mm) for the various needs.
- The highly accurate, air-driven push-pull work.

Order example:

MCJT – 12 – 40 – 25(M) – BSP

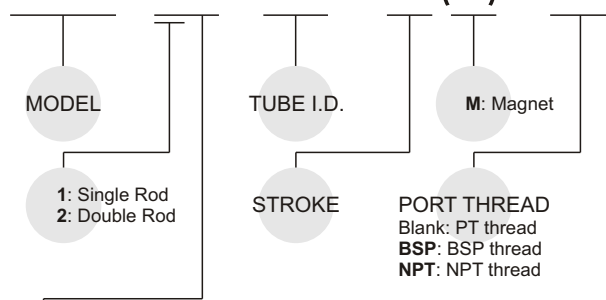

STYLE:

Code	Symbol	Description
1 1		Double acting / Male thread
1 2		Double acting / Female thread
1 3		Single acting / Normally extended male thread
1 4		Single acting / Normally extended female thread
1 5		Single acting / Normally returned male thread
1 6		Single acting / Normally returned female thread
2 1		Dual rod / Male thread
2 2		Dual rod / Female thread
2 7		Dual rod / Adjustable male thread
2 8		Dual rod / Adjustable female thread

Model	MCJT									
Acting type	Double acting / Single acting						Double acting			
Tube I.D. (mm)	12	16	20	25	32	40	50	63	80	100
Port size RC(PT)	M5 × 0.8			PT 1/8		PT 1/4		PT 3/8		
Medium	Air									
Operating pressure Kg/cm ²	Double acting		0.5~9.9		0.3~9.9		0.2~9.9			
	Single acting		2.0~9.9		1.5~9.9		1.0~9.9		—	
Proof pressure	15 kgf/cm ²									
Ambient temperature	-5~+60°C (No freezing)									
Sensor switch	RCB, RCE, RCE1									

Double acting - Table for standard stroke

	Tube I.D.	Stroke (mm)	Max. stroke
Single rod	ϕ 12, ϕ 16	5, 10, 15, 20, 25, 30	300
	ϕ 20, 25, 32, ϕ 40, 50, 63	5, 10, 15, 20, 25, 30, 35, 40, 45, 50	300
	ϕ 80~100	5, 10, 15, 20, 25, 30, 35, 40, 45, 50	125
Dual rod	ϕ 12, ϕ 16	5, 10, 15, 20, 25, 30	300
	ϕ 20, 25, 32, ϕ 40, 50, 63	5, 10, 15, 20, 25, 30, 35, 40, 45, 50	300
	ϕ 80~100	5, 10, 15, 20, 25, 30, 35, 40, 45, 50	125

- Stroke out of specification is also available.
- Please consult us if stroke out of specification.

Single acting - Table for standard stroke

Tube I.D.	Stroke (mm)
ϕ 12, 16, 20, 25, 32, 40	5, 10
ϕ 50	10, 20

Double acting

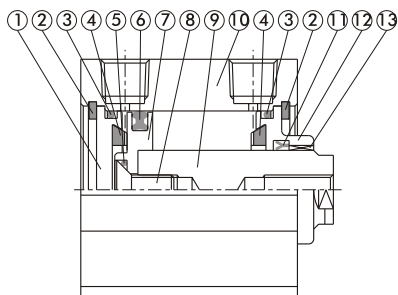

Single acting Normally returned

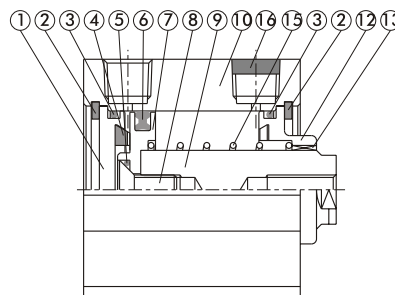

Single acting Normally extended

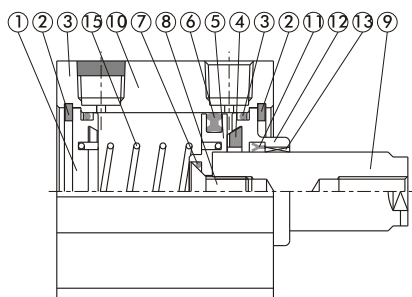

Double acting (with magnet)

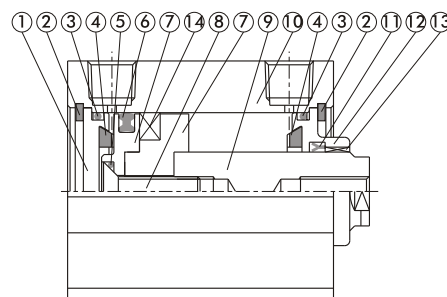

Seal kit

Acting type	Rod packing		Piston packing		Cover ring	Piston gasket
	Double action normally extended	Normally returned	Double action	Single action	Double action single action	Double action single action
Qty.	1	0	1	1	2	1
12	KSYR-6	—	OPA-12	OPA-12	S-12	d4 × w1
16	KSYR-8	—	OPA-16	OPA-16	S-14	d4 × w1
20	KSYR-10	—	OPA-20	OPA-20	S-18	d6 × w1
25	KSYR-12	—	OPA-25	OPA-25	S-22	d8 × w1
32	KSYR-16	—	OPA-32	OPA-32	d28 × w2	S-9
40	KSYR-16	—	OPA-40	OPA-40	S-36	S-9
50	KSYR-20	—	OPA-50	OPA-50	AS-31	S-16
63	KSYR-20	—	OPA-63	—	AS-36	S-16
80	ORA-25	—	OPA-80	—	AS-41	d20 × w1
100	SDR-30	—	OPA-100	—	S-95	S-26

Material

No.	Part name	Tube I.D.								
		12	16	20	25	32	40	50	63	80
1	Head cover	Aluminum alloy								
2	Snap ring	Spring steel								
3	Cover ring	NBR								
4	Cushion packing	—	NBR							
5	Piston gasket	NBR								
6	Piston packing	NBR								
7	Piston	Aluminum alloy								
8	Screw	SCM								
9	Piston rod	SUS			Carbon steel					
10	Body	Aluminum alloy								
11	Rod packing	NBR								
12	Rod cover	Aluminum alloy								
13	Bush	—	Teflon							
14	Magnet	Plastic								
15	Spring	SWP			—					
16	Silencer	Brass			—					

MCJT Female thread $\phi 12\sim\phi 100$

COMPACT CYLINDERS



$\phi 12, \phi 16$

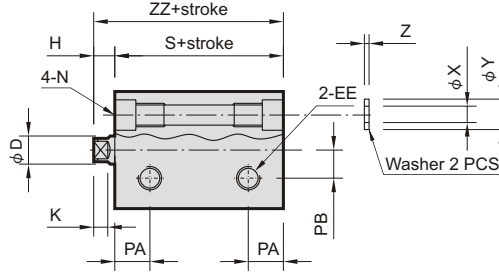
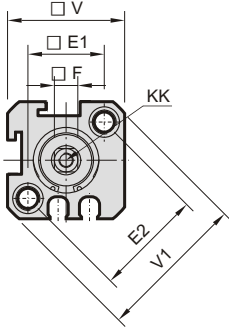

$\phi 12, \phi 16$ Long stroke
(Without counter bore)



$\phi 20\sim\phi 100$ Long stroke
(Without counter bore)



※ with magnet type: the stroke length must be over 100mm.

$\phi 20, \phi 25$

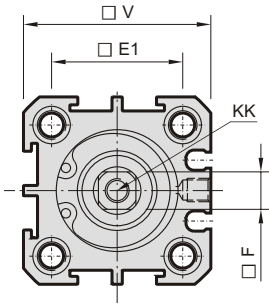

$\phi 32\sim\phi 100$

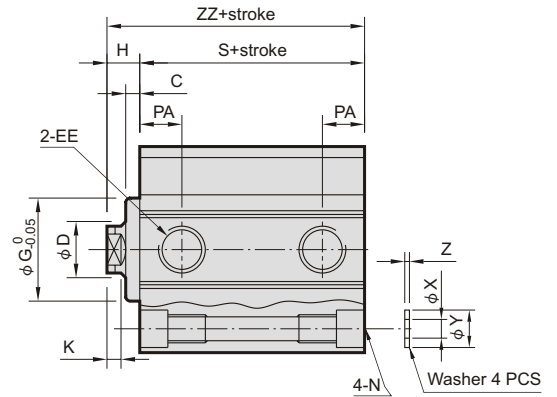
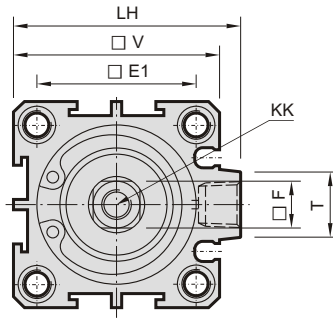

Code Tube I.D.	C	D	E1	E2	EE	F	G	H	K	KK	LH	N	PA	PB
12	-	6	16.3	23	M5×0.8	5	-	4.5	3	M3×0.5×7depth	-	6.5×4.5depth, 4.3, M5×0.8×6depth	7.5	5.5
16	-	8	19.8	28	M5×0.8	6	-	4.5	3	M4×0.7×7depth	-	6.5×4.5depth, 4.3, M5×0.8×6depth	8	6.5
20	1.5	10	24	-	M5×0.8	8	13	5.5	3	M5×0.8×10depth	-	6.5×4.5depth, 4.3, M5×0.8×7.5depth	7.5	-
25	2	12	28	-	M5×0.8	10	17	6	3	M6×1×10depth	-	8×6depth, 5.1, M6×1×9.5depth	8	-
32	3.3	16	34	-	PT 1/8(※1)	14	22	7	3	M8×1.25×12depth	48.5	8×6depth, 5.1, M6×1×8depth	9	-
40	3.3	16	40	-	PT 1/8(※1)	14	28	7	3	M8×1.25×12depth	56.5	10.5×8depth, 6.9, M8×1.25×10depth	10	-
50	4	20	48	-	PT 1/4(※2)	17	38	9	3	M10×1.5×15depth	70	11×8.5depth, 6.9, M8×1.25×10depth	10.5	-
63	4	20	60	-	PT 1/4(※2)	17	40	9	3	M10×1.5×15depth	83	11×8.5depth, 6.9, M8×1.25×10depth	11	-
80	5	25	74	-	PT 3/8(※3)	22	45	11	4	M14×2×20depth	102	14×10.5depth, 10.5, M12×1.75×12depth	13	-
100	3	30	90	-	PT 3/8(※3)	27	45	9	4	M18×2.5×20depth	122	18.5×13depth, 12.3, M14×2×15depth	15	-

※1: without magnet with stroke=5mm, EE=M5×0.8

※3: without magnet with stroke=5mm, EE=PT1/4

※2: without magnet with stroke=5mm, EE=PT1/8

Code Tube I.D.	T	V	V1	X	Y	Z	without magnet		magnet	
							S	ZZ	S	ZZ
12	-	25	32	3.2	6.3	1	20.5	25	25.5	30
16	-	29	38	3.2	6.3	1	20.5	25	30.5	35
20	-	34	-	3.2	6.3	1	19.5	25	29.5	35
25	-	40	-	4.2	7.8	1	21	27	31	37
32	14	44	-	4.2	7.8	1	24	31	34	41
40	14	52	-	6.2	10.3	1.6	26.5	33.5	36.5	43.5
50	19	62	-	6.2	10.8	1.6	28.6	37.6	38.6	47.6
63	20	75	-	6.2	10.8	1.6	32.5	41.5	42.5	51.5
80	27	94	-	8.2	13.8	1.6	41	52	51	62
100	26	114	-	10.2	17.3	2	45	54	55	64

MCJT Male thread $\phi 12\sim\phi 100$

COMPACT CYLINDERS



$\phi 12, \phi 16$

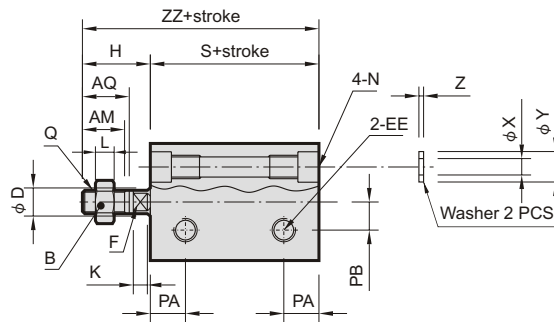
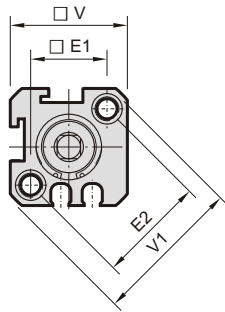

$\phi 12, \phi 16$ Long stroke
(Without counter bore)



$\phi 20\sim\phi 100$ Long stroke
(Without counter bore)



※ with magnet type: the stroke length must be over 100mm.

$\phi 20, \phi 25$

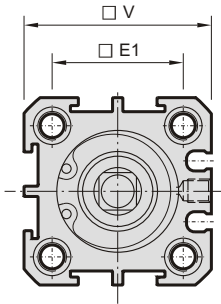

$\phi 32\sim\phi 100$

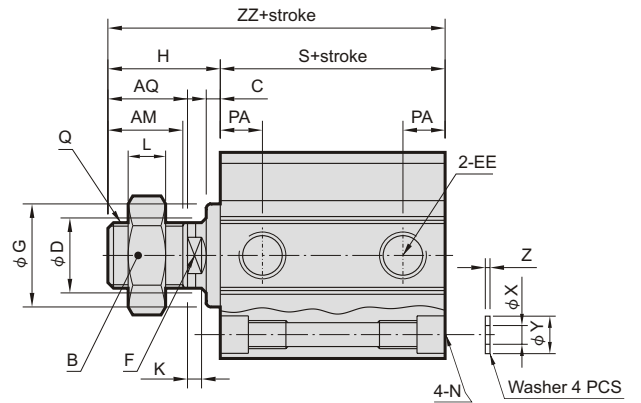
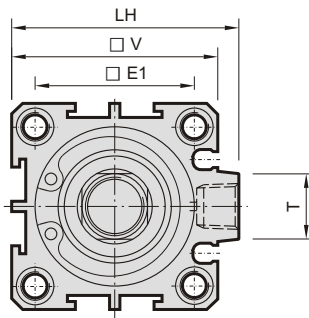

Code Tube I.D.	AM	AQ	B	C	D	E1	E2	EE	F	G	H	K	L	LH	N	PA	PB
12	9	10	8	-	6	16.3	23	M5×0.8	5	-	14.5	3	4	-	6.5×4.5depth, 4.3, M5×0.8×6depth	7.5	5.5
16	9	10	10	-	8	19.8	28	M5×0.8	6	-	14.5	3	5	-	6.5×4.5depth, 4.3, M5×0.8×6depth	8	6.5
20	13	14	13	1.5	10	24	-	M5×0.8	8	13	19.5	3	5	-	6.5×4.5depth, 4.3, M5×0.8×7.5depth	7.5	-
25	15	16	17	2	12	28	-	M5×0.8	10	17	22	3	6	-	8×6depth, 5.1, M6×1×9.5depth	8	-
32	16	17	22	3.3	16	34	-	PT 1/8(※1)	14	22	24	3	8	48.5	8×6depth, 5.1, M6×1×8depth	9	-
40	25	27	22	3.3	16	40	-	PT 1/8(※1)	14	28	34	3	8	56.5	10.5×8depth, 6.9, M8×1.25×10depth	10	-
50	25	27	26	4	20	48	-	PT 1/4(※2)	17	38	36	3	11	70	11×8.5depth, 6.9, M8×1.25×10depth	10.5	-
63	25	27	26	4	20	60	-	PT 1/4(※2)	17	40	36	3	11	83	11×8.5depth, 6.9, M8×1.25×10depth	11	-
80	30	33	32	5	25	74	-	PT 3/8(※3)	22	45	44	4	13	102	14×10.5depth, 10.5, M12×1.75×12depth	13	-
100	30	33	35	3	30	90	-	PT 3/8(※3)	27	45	42	4	14	122	18.5×13depth, 12.3, M14×2×15depth	15	-

※1: without magnet with stroke=5mm, EE=M5×0.8

※3: without magnet with stroke=5mm, EE=PT1/4

※2: without magnet with stroke=5mm, EE=PT1/8

Code Tube I.D.	Q	T	V	V1	X	Y	Z	without magnet		magnet	
								S	ZZ	S	ZZ
12	M5×0.8	-	25	32	3.2	6.3	1	20.5	35	25.5	40
16	M6×1	-	29	38	3.2	6.3	1	20.5	35	30.5	45
20	M8×1	-	34	-	3.2	6.3	1	19.5	39	29.5	49
25	M10×1.25	-	40	-	4.2	7.8	1	21	43	31	53
32	M14×1.5	14	44	-	4.2	7.8	1	24	48	34	58
40	M14×1.5	14	52	-	6.2	10.3	1.6	26.5	60.5	36.5	70.5
50	M18×1.5	19	62	-	6.2	10.8	1.6	28.6	64.6	38.6	74.6
63	M18×1.5	20	75	-	6.2	10.8	1.6	32.5	68.5	42.5	78.5
80	M22×1.5	27	94	-	8.2	13.8	1.6	41	85	51	95
100	M26×1.5	26	114	-	10.2	17.3	2	45	87	55	97

MCJT Normally returned $\phi 12\sim\phi 50$

COMPACT CYLINDERS



$\phi 12, \phi 16$

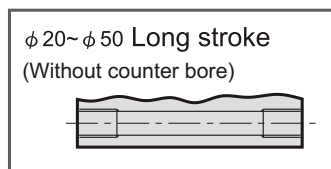
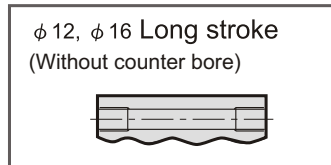
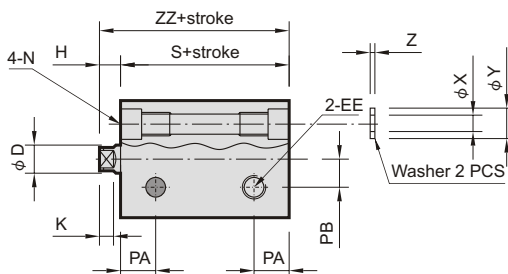
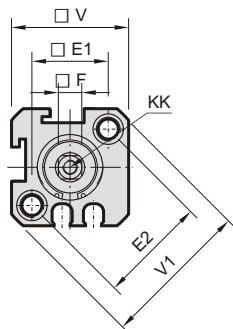

※ with magnet type: the stroke length must be over 100mm.

$\phi 20, \phi 25$

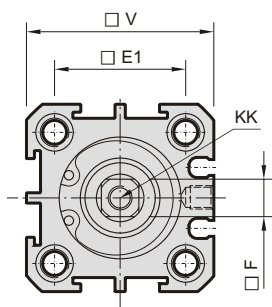

$\phi 32\sim\phi 50$

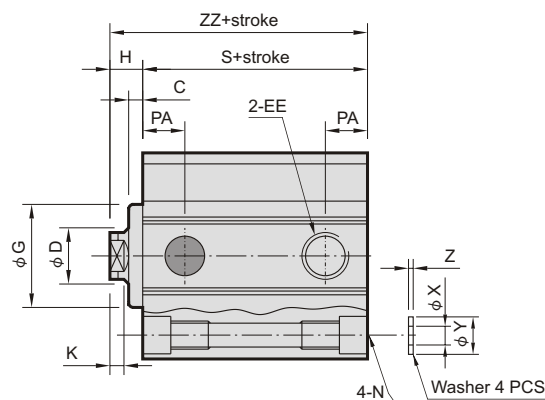
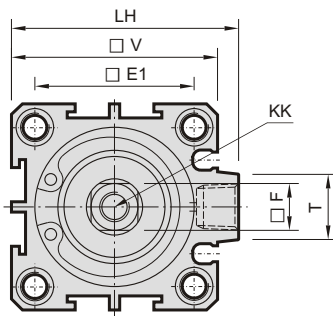

Code Tube I.D.	C	D	E1	E2	EE	F	G	H	K	KK	LH	N	PA	PB
12	-	6	16.3	23	M5×0.8	5	-	4.5	3	M3×0.5×7depth	-	6.5×4.5depth, 4.3, M5×0.8×6depth	7.5	5.5
16	-	8	19.8	28	M5×0.8	6	-	4.5	3	M4×0.7×7depth	-	6.5×4.5depth, 4.3, M5×0.8×6depth	8	6.5
20	1.5	10	24	-	M5×0.8	8	13	5.5	3	M5×0.8×10depth	-	6.5×4.5depth, 4.3, M5×0.8×7.5depth	7.5	-
25	2	12	28	-	M5×0.8	10	17	6	3	M6×1×10depth	-	8×6depth, 5.1, M6×1×9.5depth	8	-
32	3.3	16	34	-	PT 1/8(※1)	14	22	7	3	M8×1.25×12depth	48.5	8×6depth, 5.1, M6×1×8depth	9	-
40	3.3	16	40	-	PT 1/8(※1)	14	28	7	3	M8×1.25×12depth	56.5	10.5×8depth, 6.9, M8×1.25×10depth	10	-
50	4	20	48	-	PT 1/4(※2)	17	38	9	3	M10×1.5×15depth	70	11×8.5depth, 6.9, M8×1.25×10depth	10.5	-

※1: without magnet with stroke=5mm, EE=M5×0.8

※2: without magnet with stroke=5mm, EE=PT1/8

Code Tube I.D.	T	V	V1	X	Y	Z	without magnet		magnet	
							S	ZZ	S	ZZ
12	-	25	32	3.2	6.3	1	20.5	25	25.5	30
16	-	29	38	3.2	6.3	1	20.5	25	30.5	35
20	-	34	-	3.2	6.3	1	19.5	25	29.5	35
25	-	40	-	4.2	7.8	1	21	27	31	37
32	14	44	-	4.2	7.8	1	24	31	34	41
40	14	52	-	6.2	10.3	1.6	26.5	33.5	36.5	43.5
50	19	62	-	6.2	10.8	1.6	28.6	37.6	38.6	47.6

Single acting - Table for standard stroke

Tube I.D.	Stroke (mm)
$\phi 12, 16, 20, 25, 32, 40$	5, 10
$\phi 50$	10, 20

Single acting type:

Please reconfirm the dimension with our sales department when the stroke over our standard.

MCJT Normally extended $\phi 12\sim\phi 50$

COMPACT CYLINDERS



$\phi 12, \phi 16$

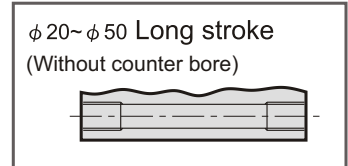
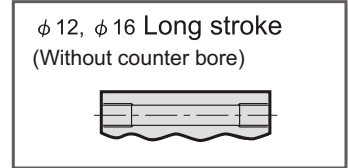
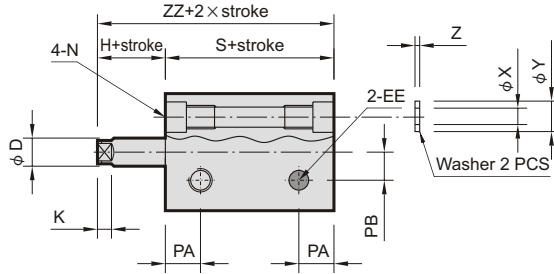
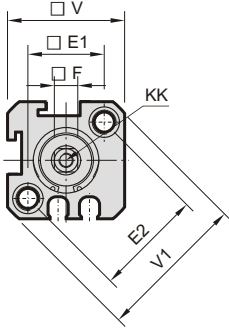

※ with magnet type: the stroke length must be over 100mm.

$\phi 20, \phi 25$

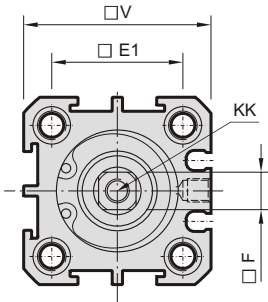

$\phi 32\sim\phi 50$

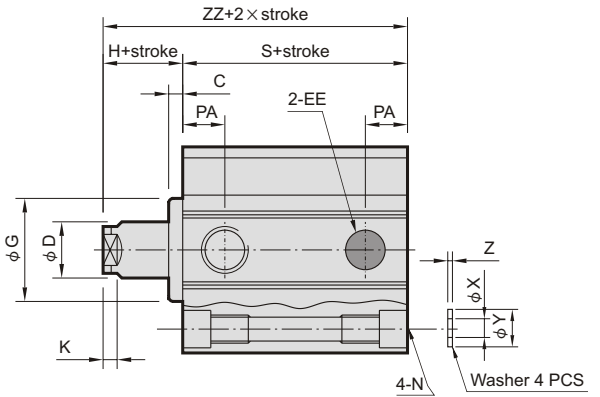
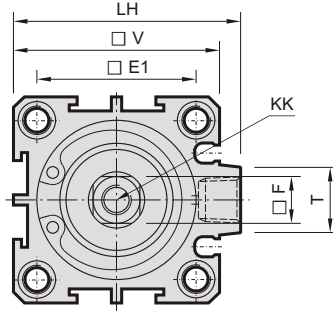

Code Tube I.D.	C	D	E1	E2	EE	F	G	H	K	KK	LH	N	PA	PB
12	-	6	16.3	23	M5×0.8	5	-	4.5	3	M3×0.5×7depth	-	6.5×4.5depth, 4.3, M5×0.8×6depth	7.5	5.5
16	-	8	19.8	28	M5×0.8	6	-	4.5	3	M4×0.7×7depth	-	6.5×4.5depth, 4.3, M5×0.8×6depth	8	6.5
20	1.5	10	24	-	M5×0.8	8	13	5.5	3	M5×0.8×10depth	-	6.5×4.5depth, 4.3, M5×0.8×7.5depth	7.5	-
25	2	12	28	-	M5×0.8	10	17	6	3	M6×1×10depth	-	8×6depth, 5.1, M6×1×9.5depth	8	-
32	3.3	16	34	-	PT 1/8(※1)	14	22	7	3	M8×1.25×12depth	48.5	8×6depth, 5.1, M6×1×8depth	9	-
40	3.3	16	40	-	PT 1/8(※1)	14	28	7	3	M8×1.25×12depth	56.5	10.5×8depth, 6.9, M8×1.25×10depth	10	-
50	4	20	48	-	PT 1/4(※2)	17	38	9	3	M10×1.5×15depth	70	11×8.5depth, 6.9, M8×1.25×10depth	10.5	-

※1: without magnet with stroke=5mm, EE=M5×0.8
 ※2: without magnet with stroke=5mm, EE=PT1/8

Code Tube I.D.	T	V	V1	X	Y	Z	without magnet		magnet	
							S	ZZ	S	ZZ
12	-	25	32	3.2	6.3	1	20.5	25	25.5	30
16	-	29	38	3.2	6.3	1	20.5	25	30.5	35
20	-	34	-	3.2	6.3	1	19.5	25	29.5	35
25	-	40	-	4.2	7.8	1	21	27	31	37
32	14	44	-	4.2	7.8	1	24	31	34	41
40	14	52	-	6.2	10.3	1.6	26.5	33.5	36.5	43.5
50	19	62	-	6.2	10.8	1.6	28.6	37.6	38.6	47.6

Single acting - Table for standard stroke

Tube I.D.	Stroke (mm)
$\phi 12, 16, 20, 25, 32, 40$	5, 10
$\phi 50$	10, 20

Single acting type:

Please reconfirm the dimension with our sales department when the stroke over our standard.

MCJT Double end rod Inside structure & Parts list

COMPACT CYLINDERS



Double acting
Double end rod type

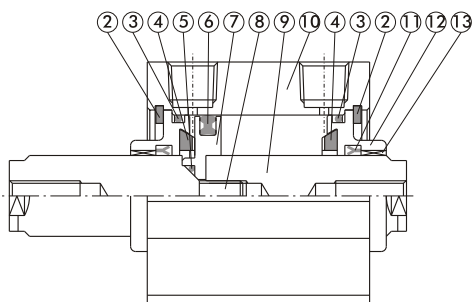

Single acting
Double end rod type

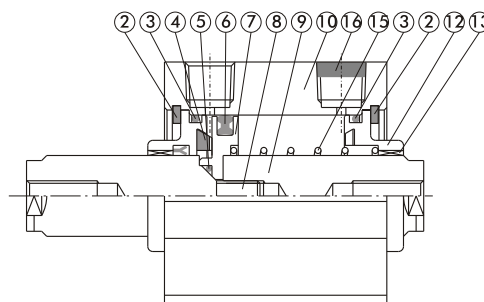

Double acting
Double end rod type(with magnet)

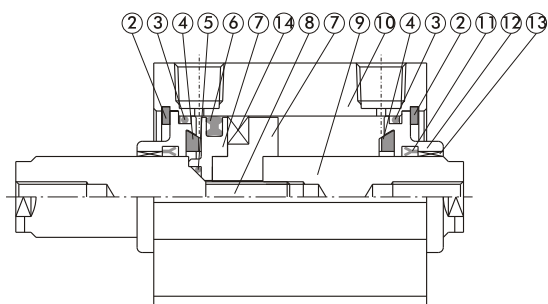

Double acting/double end rod type
Adjustable stroke

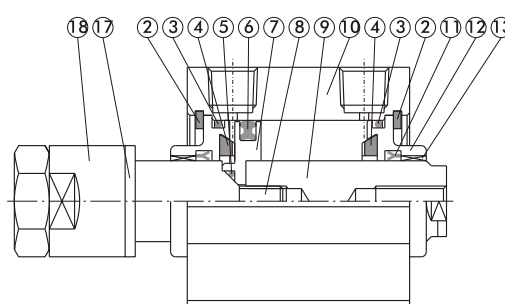

Seal kit

Acting type	Rod packing		Piston packing		Cover ring	Piston gasket
	Double action normally extended	Normally returned	Double action	Single action	Double action single action	Double action single action
Qty.	2	1	1	1	2	1
12	KSYR-6	KSYR-6	OPA-12	OPA-12	S-12	d4 × w1
16	KSYR-8	KSYR-8	OPA-16	OPA-16	S-14	d4 × w1
20	KSYR-10	KSYR-10	OPA-20	OPA-20	S-18	d6 × w1
25	KSYR-12	KSYR-12	OPA-25	OPA-25	S-22	d8 × w1
32	KSYR-16	KSYR-16	OPA-32	OPA-32	d28 × w2	S-9
40	KSYR-16	KSYR-16	OPA-40	OPA-40	S-36	S-9
50	KSYR-20	KSYR-20	OPA-50	OPA-50	AS-31	S-16
63	KSYR-20	—	OPA-63	—	AS-36	S-16
80	ORA-25	—	OPA-80	—	AS-41	d20 × w1
100	SDR-30	—	OPA-100	—	S-95	S-26

Material

No.	Part name	Tube I.D.									
		12	16	20	25	32	40	50	63	80	100
1	—	—									
2	Snap ring	Spring steel									
3	Cover ring	NBR									
4	Cushion packing	—	NBR								
5	Piston gasket	NBR									
6	Piston packing	NBR									
7	Piston	Aluminum alloy									
8	Screw	SCM									
9	Piston rod	SUS					Carbon steel				
10	Body	Aluminum alloy									
11	Rod packing	NBR									
12	Rod cover	Aluminum alloy									
13	Bush	—	Teflon								
14	Magnet	PLASTIC									
15	Spring	SWP								—	
16	Silencer	Brass								—	
17	Cushion packing	PU									
18	Adjustable nut	Spring steel									

MCJT Double end rod / Female thread $\phi 12 \sim \phi 100$

COMPACT CYLINDERS



$\phi 12, \phi 16$

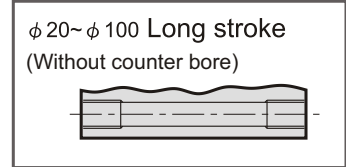
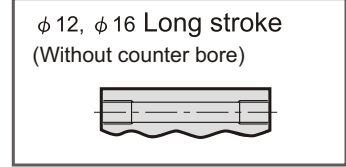
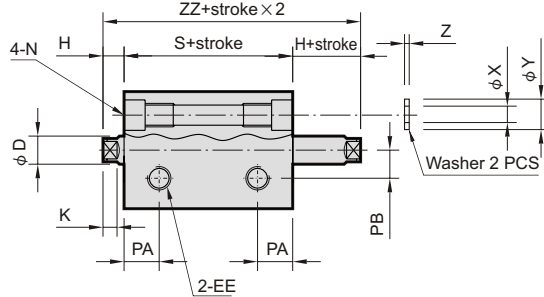
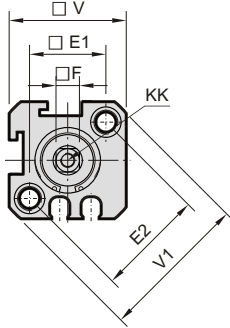

※ with magnet type: the stroke length must be over 100mm.

$\phi 20, \phi 25$

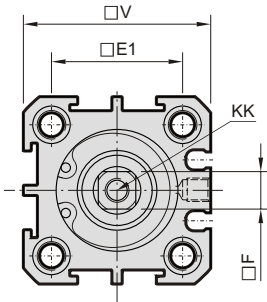

$\phi 32 \sim \phi 100$

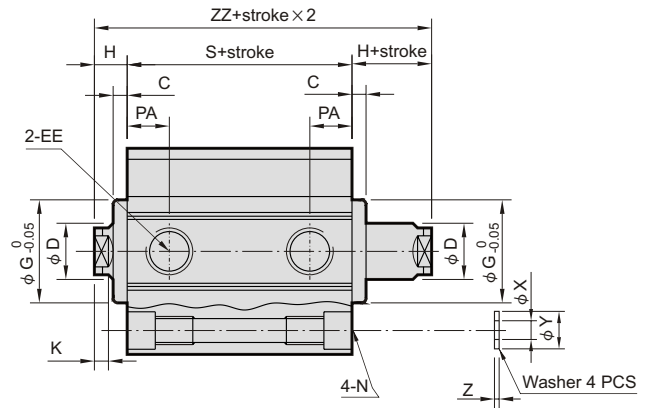
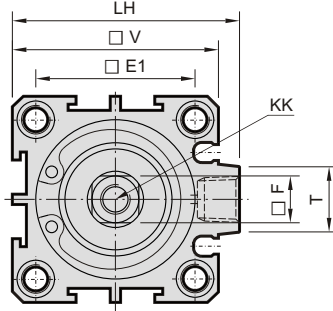

Code Tube I.D.	C	D	E1	E2	EE	F	G	H	K	KK	LH	N	PA	PB
12	-	6	16.3	23	M5×0.8	5	-	4.5	3	M3×0.5×7depth	-	6.5×4.5depth, 4.3, M5×0.8×6depth	7.5	5.5
16	-	8	19.8	28	M5×0.8	6	-	4.5	3	M4×0.7×7depth	-	6.5×4.5depth, 4.3, M5×0.8×6depth	8	6.5
20	1.5	10	24	-	M5×0.8	8	13	5.5	3	M5×0.8×10depth	-	6.5×4.5depth, 4.3, M5×0.8×7.5depth	7.5	-
25	2	12	28	-	M5×0.8	10	17	6	3	M6×1×10depth	-	8×6depth, 5.1, M6×1×9.5depth	8	-
32	3.3	16	34	-	PT 1/8(※1)	14	22	7	3	M8×1.25×12depth	48.5	8×6depth, 5.1, M6×1×8depth	9	-
40	3.3	16	40	-	PT 1/8(※1)	14	28	7	3	M8×1.25×12depth	56.5	10.5×8depth, 6.9, M8×1.25×10depth	10	-
50	4	20	48	-	PT 1/4(※2)	17	38	9	3	M10×1.5×15depth	70	11×8.5depth, 6.9, M8×1.25×10depth	10.5	-
63	4	20	60	-	PT 1/4(※2)	17	40	9	3	M10×1.5×15depth	83	11×8.5depth, 6.9, M8×1.25×10depth	11	-
80	5	25	74	-	PT 3/8(※3)	22	45	11	4	M14×2×20depth	102	14×10.5depth, 10.5, M12×1.75×12depth	13	-
100	3	30	90	-	PT 3/8(※3)	27	45	9	4	M18×2.5×20depth	122	18.5×13depth, 12.3, M14×2×15depth	15	-

※1: without magnet with stroke=5mm, EE=M5×0.8

※3: without magnet with stroke=5mm, EE=PT1/4

※2: without magnet with stroke=5mm, EE=PT1/8

Code Tube I.D.	T	V	V1	X	Y	Z	without magnet		magnet	
							S	ZZ	S	ZZ
12	-	25	32	3.2	6.3	1	20.5	29.5	25.5	34.5
16	-	29	38	3.2	6.3	1	20.5	29.5	30.5	39.5
20	-	34	-	3.2	6.3	1	19.5	30.5	29.5	40.5
25	-	40	-	4.2	7.8	1	21	33	31	43
32	14	44	-	4.2	7.8	1	24	38	34	48
40	14	52	-	6.2	10.3	1.6	26.5	40.5	36.5	50.5
50	19	62	-	6.2	10.8	1.6	28.6	46.6	38.6	56.6
63	20	75	-	6.2	10.8	1.6	32.5	50.5	42.5	60.5
80	27	94	-	8.2	13.8	1.6	41	63	51	73
100	26	114	-	10.2	17.3	2	45	63	55	73

MCJT Double end rod / Single acting $\phi 12\sim\phi 50$

COMPACT CYLINDERS



$\phi 12, \phi 16$

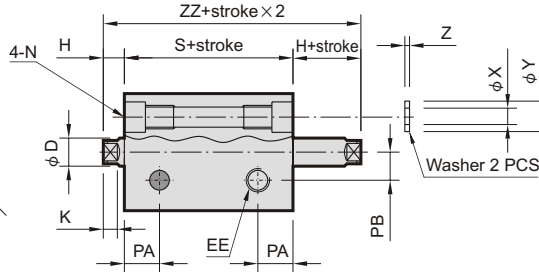
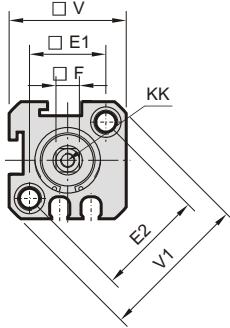

$\phi 12, \phi 16$ Long stroke
(Without counter bore)



$\phi 20\sim\phi 50$ Long stroke
(Without counter bore)

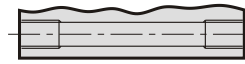

※ with magnet type: the stroke length must be over 100mm.

$\phi 20, \phi 25$

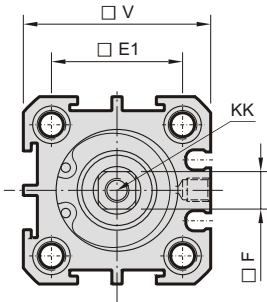

$\phi 32\sim\phi 50$

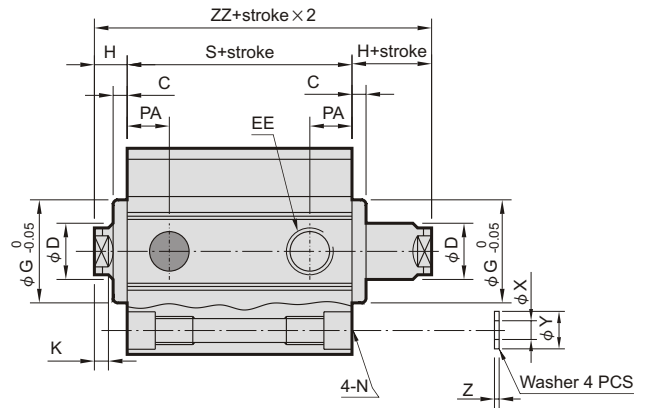
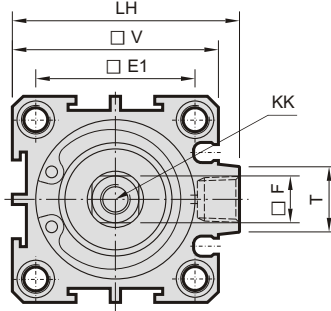

Code Tube I.D.	C	D	E1	E2	EE	F	G	H	K	KK	LH	N	PA	PB
12	-	6	16.3	23	M5×0.8	5	-	4.5	3	M3×0.5×7depth	-	6.5×4.5depth, 4.3, M5×0.8×6depth	7.5	5.5
16	-	8	19.8	28	M5×0.8	6	-	4.5	3	M4×0.7×7depth	-	6.5×4.5depth, 4.3, M5×0.8×6depth	8	6.5
20	1.5	10	24	-	M5×0.8	8	13	5.5	3	M5×0.8×10depth	-	6.5×4.5depth, 4.3, M5×0.8×7.5depth	7.5	-
25	2	12	28	-	M5×0.8	10	17	6	3	M6×1×10depth	-	8×6depth, 5.1, M6×1×9.5depth	8	-
32	3.3	16	34	-	PT 1/8(※1)	14	22	7	3	M8×1.25×12depth	48.5	8×6depth, 5.1, M6×1×8depth	9	-
40	3.3	16	40	-	PT 1/8(※1)	14	28	7	3	M8×1.25×12depth	56.5	10.5×8depth, 6.9, M8×1.25×10depth	10	-
50	4	20	48	-	PT 1/4(※2)	17	38	9	3	M10×1.5×15depth	70	11×8.5depth, 6.9, M8×1.25×10depth	10.5	-

※1: without magnet with stroke=5mm, EE=M5×0.8

※2: without magnet with stroke=5mm, EE=PT1/8

Code Tube I.D.	T	V	V1	X	Y	Z	without magnet		magnet	
							S	ZZ	S	ZZ
12	-	25	32	3.2	6.3	1	20.5	29.5	25.5	34.5
16	-	29	38	3.2	6.3	1	20.5	29.5	30.5	39.5
20	-	34	-	3.2	6.3	1	19.5	30.5	29.5	40.5
25	-	40	-	4.2	7.8	1	21	33	31	43
32	14	44	-	4.2	7.8	1	24	38	34	48
40	14	52	-	6.2	10.3	1.6	26.5	40.5	36.5	50.5
50	19	62	-	6.2	10.8	1.6	28.6	46.6	38.6	56.6

Single acting - Table for standard stroke

Tube I.D.	Stroke (mm)
$\phi 12, 16, 20, 25, 32, 40$	5, 10
$\phi 50$	10, 20

Single acting type:

Please reconfirm the dimension with our sales department when the stroke over our standard.

MCJT Double end rod / Adjustable stroke $\phi 12\sim\phi 100$

COMPACT CYLINDERS



$\phi 12, \phi 16$

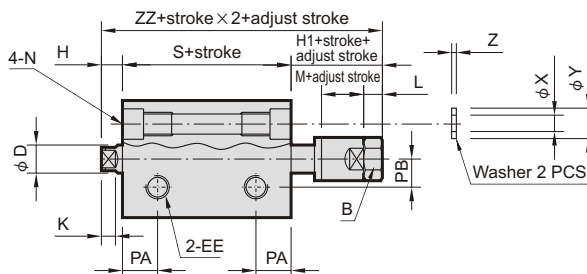
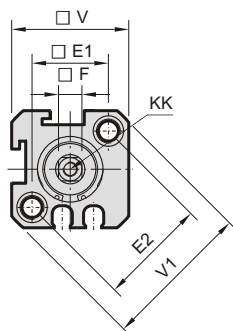

$\phi 12, \phi 16$ Long stroke
(Without counter bore)



$\phi 20\sim\phi 100$ Long stroke
(Without counter bore)



※ with magnet type: the stroke length must be over 100mm.

$\phi 20, \phi 25$

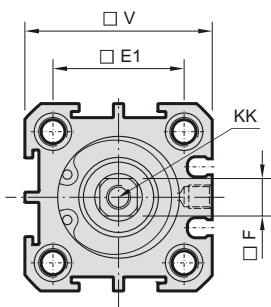

$\phi 32\sim\phi 100$

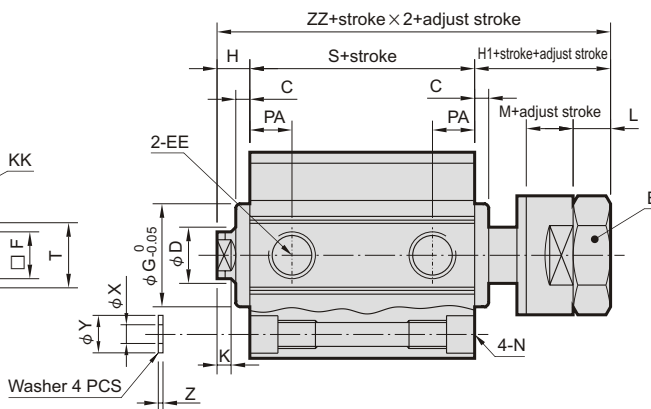
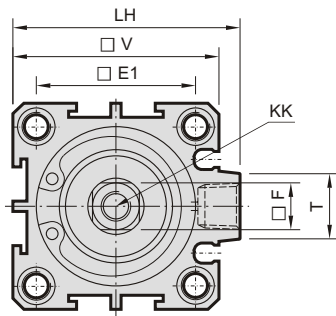

Code Tube I.D.	B	C	D	E1	E2	EE	F	G	H	H1	K	KK	L	LH	M	N
12	8	-	6	16.3	23	M5×0.8	5	-	4.5	19.5	3	M3×0.5×7depth	4	-	13	6.5×4.5depth, 4.3, M5×0.8×6depth
16	13	-	8	19.8	28	M5×0.8	6	-	4.5	22.5	3	M4×0.7×7depth	5	-	15	6.5×4.5depth, 4.3, M5×0.8×6depth
20	13	1.5	10	24	-	M5×0.8	8	13	5.5	25.5	3	M5×0.8×10depth	5	-	15	6.5×4.5depth, 4.3, M5×0.8×7.5depth
25	17	2	12	28	-	M5×0.8	10	17	6	26	3	M6×1×10depth	6	-	12	8×6depth, 5.1, M6×1×9.5depth
32	19	3.3	16	34	-	PT 1/8(※1)	14	22	7	28	3	M8×1.25×12depth	7	48.5	12	8×6depth, 5.1, M6×1×8depth
40	19	3.3	16	40	-	PT 1/8(※1)	14	28	7	28.3	3	M8×1.25×12depth	7	56.5	12	10.5×8depth, 6.9, M8×1.25×10depth
50	24	4	20	48	-	PT 1/4(※2)	17	38	9	31	3	M10×1.5×15depth	8	70	15	11×8.5depth, 6.9, M8×1.25×10depth
63	24	4	20	60	-	PT 1/4(※2)	17	40	9	31	3	M10×1.5×15depth	8	83	15	11×8.5depth, 6.9, M8×1.25×10depth
80	32	5	25	74	-	PT 3/8(※3)	22	45	11	44	4	M14×2×20depth	13	102	20	14×10.5depth, 10.5, M12×1.75×12depth
100	32	3	30	90	-	PT 3/8(※3)	27	45	9	40	4	M18×2.5×20depth	13	122	20	18.5×13depth, 12.3, M14×2×15depth

※1: without magnet with stroke=5mm, EE=M5×0.8

※3: without magnet with stroke=5mm, EE=PT1/4

※2: without magnet with stroke=5mm, EE=PT1/8

Code Tube I.D.	PA	PB	T	V	X	Y	Z	without magnet		magnet	
								S	ZZ	S	ZZ
12	7.5	5.5	-	25	3.2	6.3	1	20.5	44.5	25.5	49.5
16	8	6.5	-	29	3.2	6.3	1	20.5	47.5	30.5	57.5
20	7.5	-	-	34	3.2	6.3	1	19.5	50.5	29.5	60.5
25	8	-	-	40	4.2	7.8	1	21	53	31	63
32	9	-	14	44	4.2	7.8	1	24	59	34	69
40	10	-	14	52	6.2	10.3	1.6	26.5	61.8	36.5	71.8
50	10.5	-	19	62	6.2	10.8	1.6	28.6	58.6	38.6	78.6
63	11	-	20	75	6.2	10.8	1.6	32.5	72.5	42.5	82.5
80	13	-	27	94	8.2	13.8	1.6	41	96	51	106
100	15	-	26	114	10.2	17.3	2	45.5	94	55.5	104

MCJT Double end rod / Single action / Adjustable stroke $\phi 12\sim\phi 50$

COMPACT CYLINDERS



$\phi 12, \phi 16$

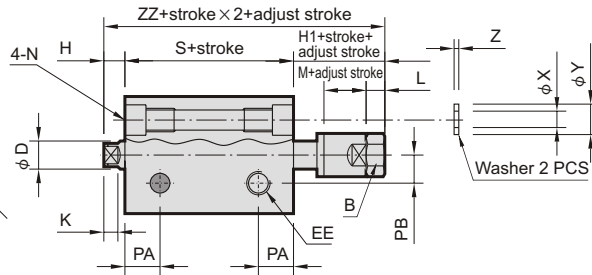
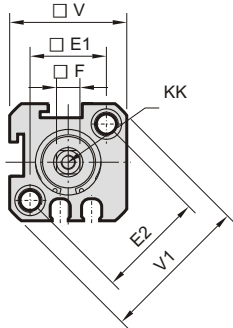

$\phi 12, \phi 16$ Long stroke
(Without counter bore)



$\phi 20\sim\phi 50$ Long stroke
(Without counter bore)



※ with magnet type: the stroke length must be over 100mm.

$\phi 20, \phi 25$

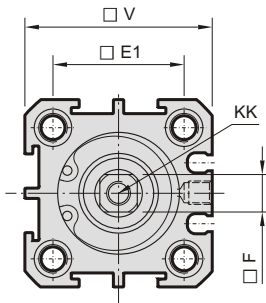

$\phi 32\sim\phi 50$

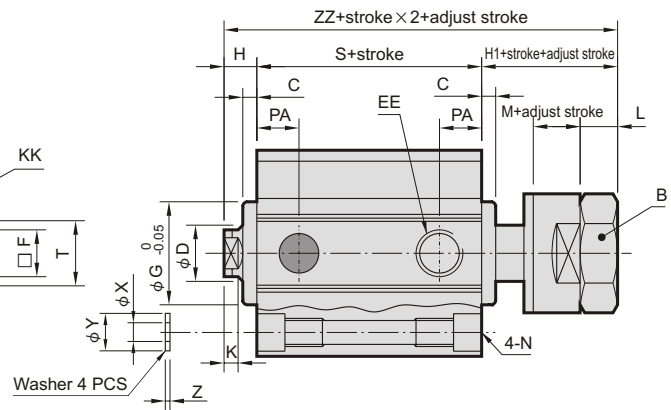
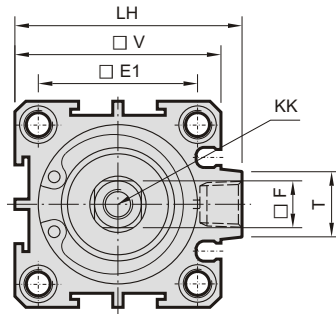

Code Tube I.D.	B	C	D	E1	E2	EE	F	G	H	H1	K	KK	L	LH	M	N
12	8	-	6	16.3	23	M5×0.8	5	-	4.5	19.5	3	M3×0.5×7depth	4	-	13	6.5×4.5depth, 4.3, M5×0.8×6depth
16	13	-	8	19.8	28	M5×0.8	6	-	4.5	22.5	3	M4×0.7×7depth	5	-	15	6.5×4.5depth, 4.3, M5×0.8×6depth
20	13	1.5	10	24	-	M5×0.8	8	13	5.5	25.5	3	M5×0.8×10depth	5	-	15	6.5×4.5depth, 4.3, M5×0.8×7.5depth
25	17	2	12	28	-	M5×0.8	10	17	6	26	3	M6×1×10depth	6	-	12	8×6depth, 5.1, M6×1×9.5depth
32	19	3.3	16	34	-	PT 1/8(※1)	14	22	7	28	3	M8×1.25×12depth	7	48.5	12	8×6depth, 5.1, M6×1×8depth
40	19	3.3	16	40	-	PT 1/8(※1)	14	28	7	28.3	3	M8×1.25×12depth	7	56.5	12	10.5×8depth, 6.9, M8×1.25×10depth
50	24	4	20	48	-	PT 1/4(※2)	17	38	9	31	3	M10×1.5×15depth	8	70	15	11×8.5depth, 6.9, M8×1.25×10depth

※1: without magnet with stroke=5mm, EE=M5×0.8

※2: without magnet with stroke=5mm, EE=PT1/8

Code Tube I.D.	PA	PB	T	V	X	Y	Z	without magnet		magnet	
								S	ZZ	S	ZZ
12	7.5	5.5	-	25	3.2	6.3	1	20.5	44.5	25.5	49.5
16	8	6.5	-	29	3.2	6.3	1	20.5	47.5	30.5	57.5
20	7.5	-	-	34	3.2	6.3	1	19.5	50.5	29.5	60.5
25	8	-	-	40	4.2	7.8	1	21	53	31	63
32	9	-	14	44	4.2	7.8	1	24	59	34	69
40	10	-	14	52	6.2	10.3	1.6	26.5	61.8	36.5	71.8
50	10.5	-	19	62	6.2	10.8	1.6	28.6	58.6	38.6	78.6

Single acting - Table for standard stroke

Tube I.D.	Stroke (mm)
$\phi 12, 16, 20, 25, 32, 40$	5, 10
$\phi 50$	10, 20

Single acting type:

Please reconfirm the dimension with our sales department when the stroke over our standard.

MCJT Installation of sensor switch $\phi 12 \sim \phi 100$

COMPACT CYLINDERS



Dimensions:

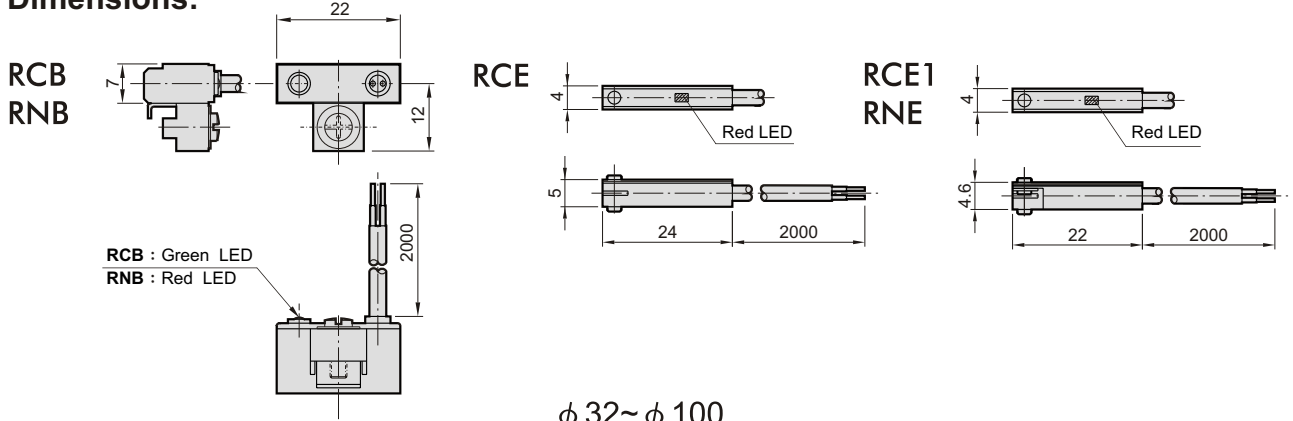

Installation of sensor switch:

$\phi 12, \phi 16$

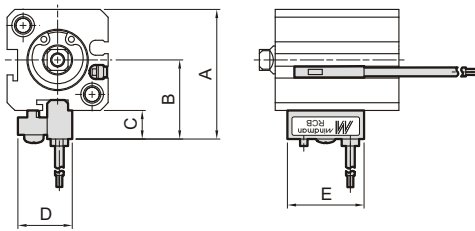

$\phi 32 \sim \phi 100$

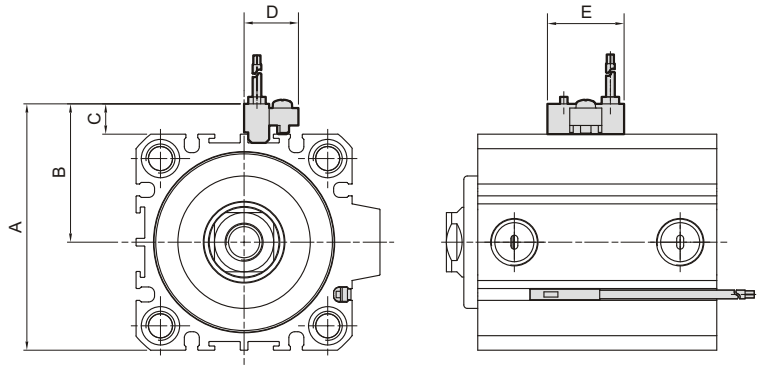

Order example:

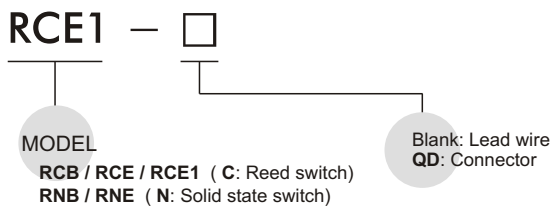

Code Tube I.D.	A	B	C	D	E
12	33.5	21.5	8.5	16	22
16	37.5	23	8.5	16	22
20	42.5	25.5	8.5	16	22
25	49	29	9	16	22
32	53	31	9	16	22

Code Tube I.D.	A	B	C	D	E
40	61	35	9	16	22
50	71	40	9	16	22
63	84	46.5	9	16	22
80	103	56	9	16	22
100	123	66	9	16	22

Description:

- ▽ RCB switch
- ▽ RCE, RCE1 switch

