

MCMA series

MINIATURE CYLINDERS



Features:

- Non-lubrication:**
 Designs of oil-filled alloy, special housing and bushing provide the needed self-lubrication of piston rod.
- High quality-long service life:**
 Stainless cylinder tubes resist corrosion and abrasion.
- Cylinder mountings:**
 Available with a comprehensive selection of mountings for fixed or flexible installation.
- Acting type:**
 Except MCMA-11 (standard type), available with MCMA-13, -15 (single acting), MCMA-21-SDW (dual rod type), MCMA-27-SDJ (stroke adjustable type)
- Standard with magnet.**

Table for standard stroke

	Tube I.D.	Stroke (mm)	Max. stroke
Single Acting	φ 16	15, 25, 50, 75, 100	
	φ 20, 25, 32	15, 25, 50, 75, 100, 125, 150	
Double Acting	φ 16	15, 25, 50, 75, 100, 125, 150, 200, 250, 300, 350, 400, 450, 500	900
	φ 20, 25, 32, 40	15, 25, 50, 75, 100, 125, 150, 200, 250, 300, 350, 400, 450, 500	900

- Stroke out of specification is also available.
- Please consult us if stroke out of specification.

Model	MCMA				
Tube I.D. (mm)	16	20	25	32	40
Port size	M5×0.8 PT 1/8				
Medium	Air				
Max operating pressure	7 kgf/cm ²				
Min. operating pressure	Double	0.6 kgf/cm ²			
	Single	1.5 kgf/cm ²			
Proof pressure	10 kgf/cm ²				
Available speed range	50~500 mm/sec				
Ambient temperature	-5~+60°C (No freezing)				
Lubricator	Not required				
Sensor switch (band)	RCA (Matching the BA20~BA40 band) (Matching the BGS20~BGS40 band)				
	RCM (Matching the BM16~BM40 band)				
	RCS (Matching the BJ16 band)				

● The code of sensor switch band is BM16. "16" represents the tube I.D.

Order example:

MCMA - 11 - 32 - 100 - A - N - BSP

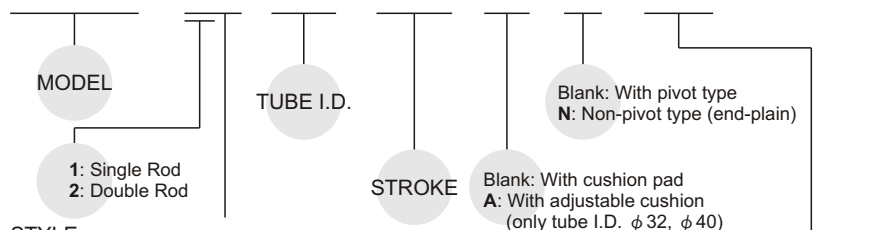

STYLE:

Code	Symbol	Description
1 1		Double acting / Male thread
1 3		Single acting / Normally extended male thread
1 5		Single acting / Normally returned male thread
2 1		Dual rod / Male thread
2 7		Dual rod / Adjustable male thread Please mark "adjustable distance(mm)" at order list

Mounting accessories:

FA - MCMA - 32

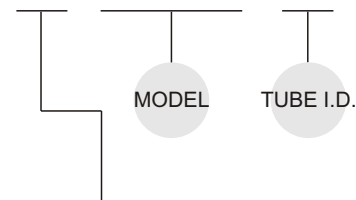

PORT THREAD
Blank: PT thread
BSP: BSP thread
NPT: NPT thread

MOUNTING TYPE

	LB
	FA
	FB
	SDB

Double acting

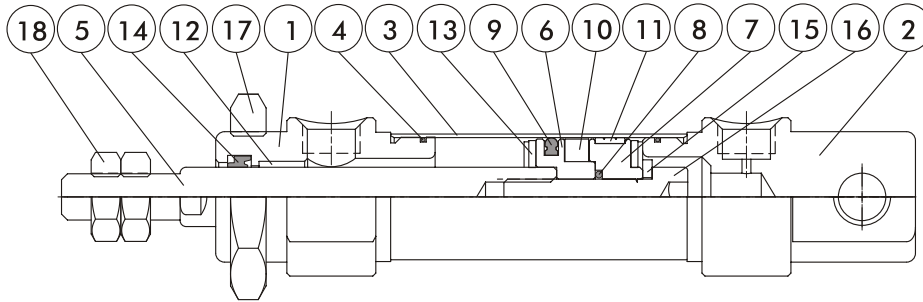

Material

No.	Part name	Material	Note
1	Rod cover	Aluminum alloy	
2	Head cover	Aluminum alloy	
3	Tube	Stainless steel	
4	Cover ring	NBR	
5	Piston rod	Medium carbon steel	φ 16 - Stainless steel
6	Piston-R	Aluminum alloy	φ 25 With cushion pad - Polyurethane
7	Piston-H	Aluminum alloy	φ 25 With cushion pad - Polyurethane
8	Piston gasket	NBR	
9	Piston packing	NBR	
10	Magnet ring	Magnet material	
11	Wear ring	Teflon	
12	Rod bush	Copper	
13	Cushion gasket	NBR	
14	Rod packing	NBR	
15	Washer	Carbon steel	
16	Piston lock nut	SCM	
17	Tie nut	Carbon steel	
18	Rod front nut	Carbon steel	

MCMA Dimensions / Double acting $\phi 16\sim\phi 40$

MINIATURE CYLINDERS



11

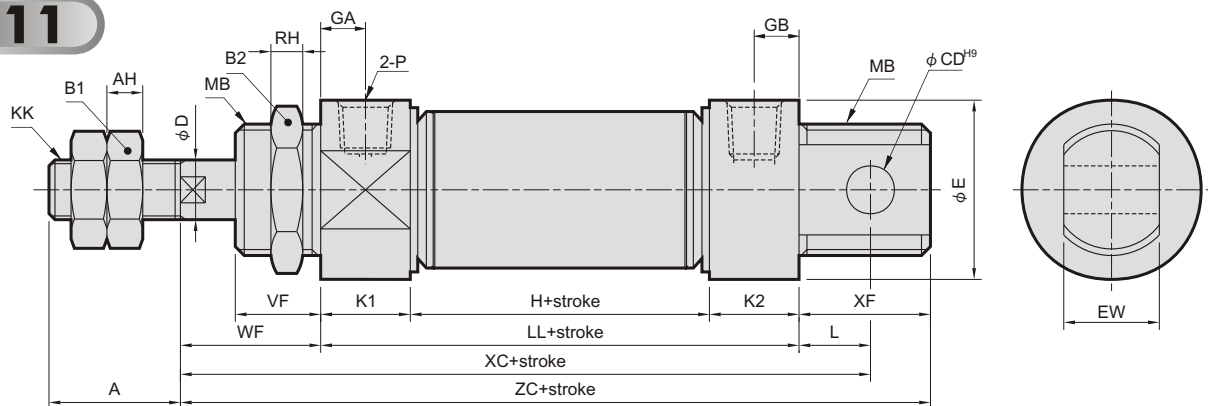

21

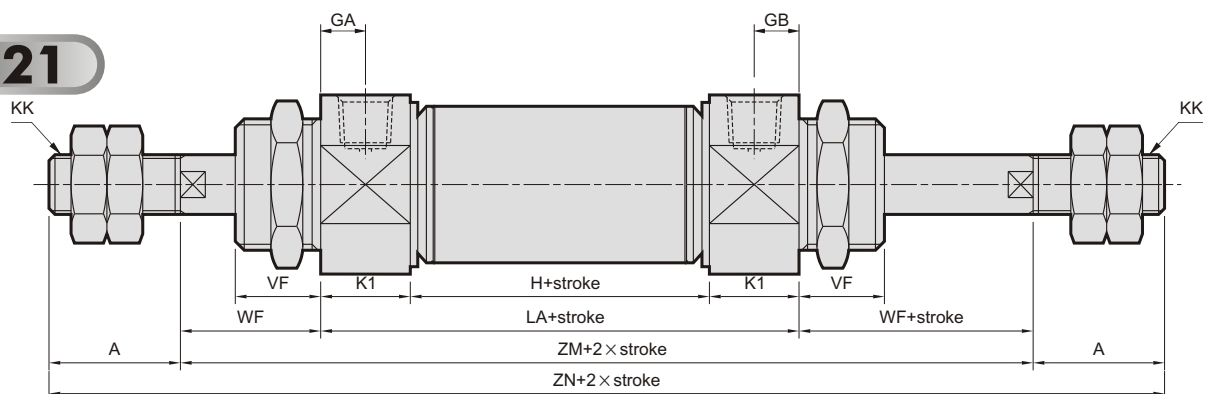

27

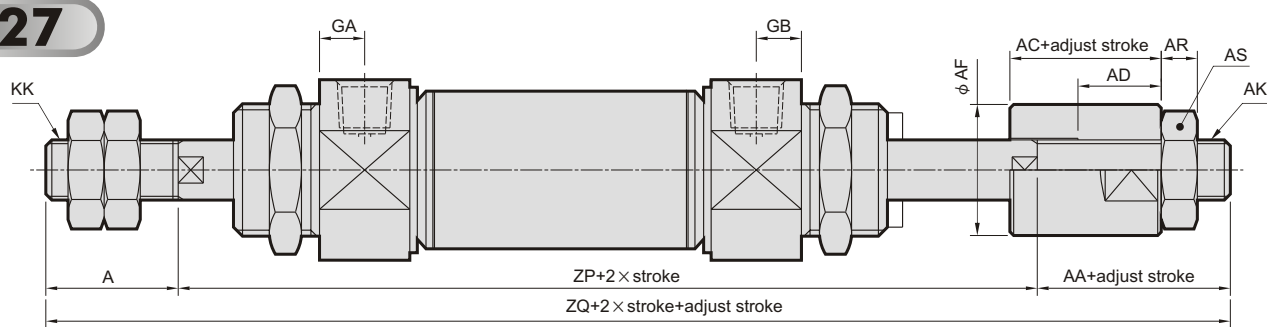

Code Tube I.D.	A	AA	AC	AD	AF	AH	AR	AS	AK	B1	B2	CD	D	E	EW	GA	GB	H	KK
16	16	16	13	7.5	12	5	4	8	M5×0.8	10	22	6	6	19.7	12 ^{-0.05} _{-0.4}	5	5	34	M6×1.0
20	20	19	15	9.5	16	5	5	13	M8×1.25	13	30	8	10	26.7	16 ^{-0.05} _{-0.4}	7.5	7.5	40	M8×1.25
25	22	19	15	9.5	16	5	5	13	M8×1.25	17	30	8	10	29.7	16 ^{-0.05} _{-0.4}	7.5	7.5	40	M10×1.25
32	22	18	12	7	20	6	6	17	M10×1.25	17	32	10	12	36	16 ^{-0.05} _{-0.4}	7.5	10.5	37	M10×1.25
40	30	18	12	7	30	7	7	19	M12×1.25	19	41	12	16	45	20 ^{-0.05} _{-0.4}	7.5	10.5	42	M12×1.25

Code Tube I.D.	K1	K2	L	LA	LL	MB	P	RH	VF	WF	XC	XF	ZC	ZM	ZN	ZP	ZQ
16	10	10	9	54	54	M16×1.5	M5×0.8	6	12	22	85	16	92	98	130	95.5	127.5
20	15	15	12	70	70	M22×1.5	PT 1/8	6	12	18	100	21	109	106	146	107.5	146.5
25	15	15	12	70	70	M22×1.5	PT 1/8	6	15	27	109	21	118	124	168	119.5	160.5
32	15	18	14	67	70	M24×2.0	PT 1/8	8	18	30	114	24	124	127	171	121	161
40	15	18	16	72	75	M30×2.0	PT 1/8	8	17	27	118	28	130	126	186	123	171

MCMA Dimensions / Double acting $\phi 16 \sim \phi 40$

MINIATURE CYLINDERS



N

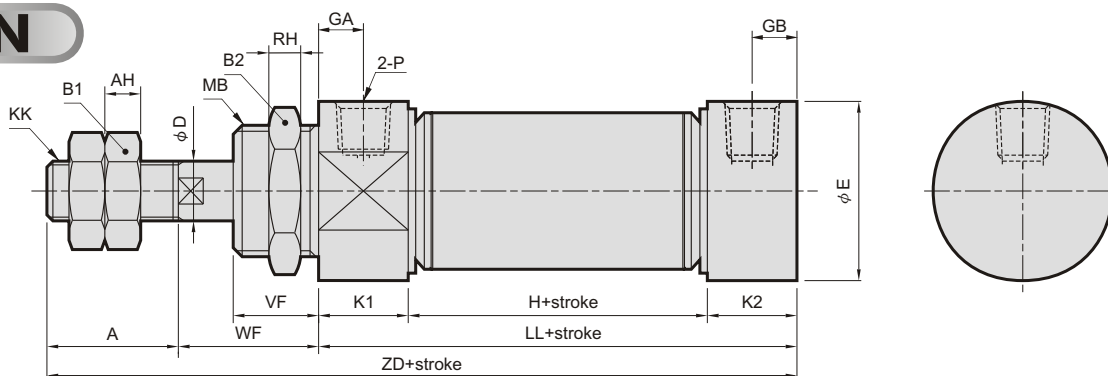

Code Tube I.D.	A	AH	B1	B2	D	E	GA	GB	H	KK	K1	K2	LL	MB	P	RH	VF	WF	ZD
16	16	5	10	22	6	19.7	5	5	34	M6×1.0	10	10	54	M16×1.5	M5×0.8	6	12	22	92
20	20	5	13	30	10	26.7	7.5	7.5	40	M8×1.25	15	15	70	M22×1.5	PT 1/8	6	12	18	108
25	22	6	17	30	10	29.7	7.5	7.5	40	M10×1.25	15	15	70	M22×1.5	PT 1/8	6	15	27	119
32	22	6	17	32	12	36	7.5	10.5	37	M10×1.25	15	18	70	M24×2.0	PT 1/8	8	18	30	122
40	30	7	19	41	16	45	7.5	10.5	42	M12×1.25	15	18	75	M30×2.0	PT 1/8	8	17	27	132

Mounting accessories

LB

MCMA- $\phi 16$

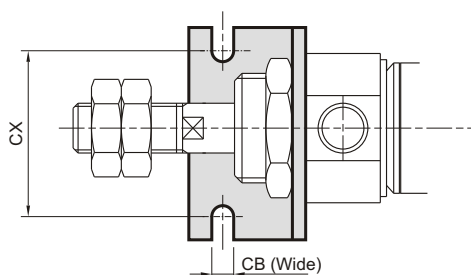

MCMA- $\phi 20 \sim \phi 40$

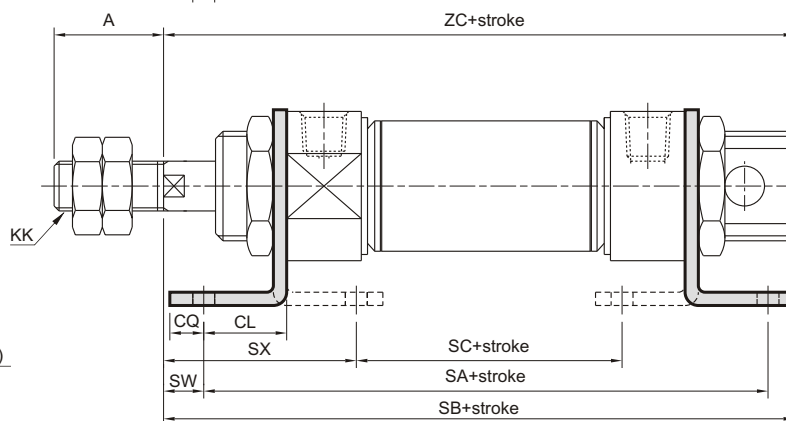
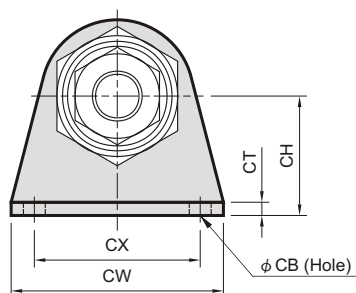

Code Tube I.D.	A	CB	CH	CL	CQ	CT	CW	CX	KK	SA	SB	SC	SW	SX	ZC
16	16	5.5	20	13	6	3.2	44	32	M6×1.0	80	95	34.4	9	31.8	92
20	20	6.6	25	15	8	3.2	54	40	M8×1.25	100	111	46.4	3	29.8	109
25	22	6.6	25	15	8	3.2	54	40	M10×1.25	100	120	46.4	12	38.8	118
32	22	6.6	32	25	8	4	59	45	M10×1.25	120	133	28	5	51	124
40	30	6.6	36	25	8	4	64	50	M12×1.25	125	135	33	2	48	130

MCMA Mounting accessories / Double acting $\phi 16 \sim \phi 40$

MINIATURE CYLINDERS



FA(FB)

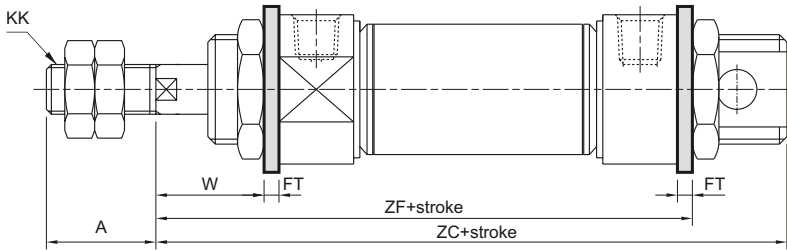

Code Tube I.D.	A	FB	FE	FF	FP	FR	FT	KK	W	ZC	ZF
16	16	5.5	26	52	40		3.2	M6×1.0	18.8	92	79.2
20	20	6.6	38	64	50		4.5	M8×1.25	13.5	109	92.5
25	22	6.6	38	64	50		4.5	M10×1.25	22.5	118	101.5
32	22	6.6	47	72	58	33	4.5	M10×1.25	25.5	124	104.5
40	30	6.6	50	84	70	36	4.5	M12×1.25	22.5	130	105.5

MCMA- $\phi 16$

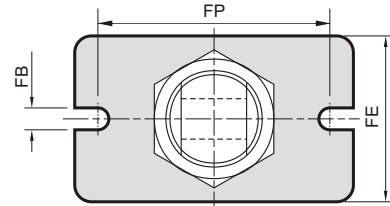

MCMA- $\phi 20, \phi 25$

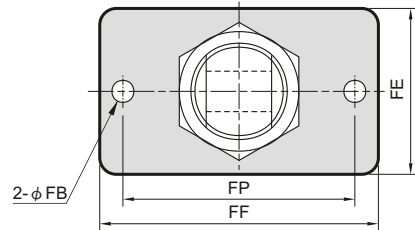

MCMA- $\phi 32, \phi 40$

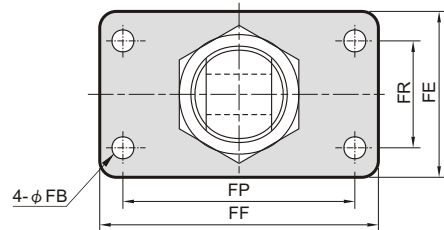

SDB

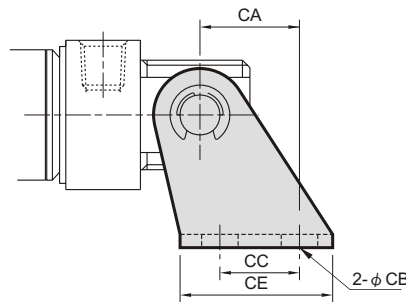

MCMA- $\phi 16$

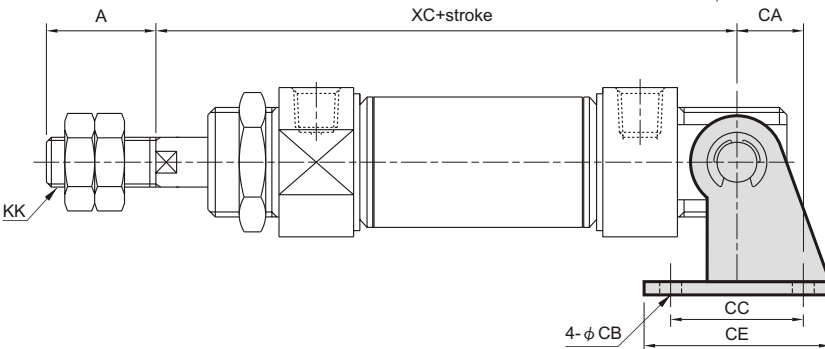
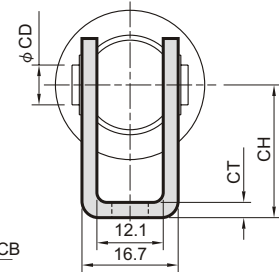

MCMA- $\phi 20 \sim \phi 40$

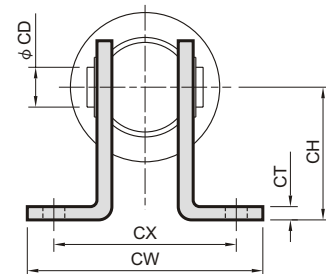

Code Tube I.D.	A	CA	CB	CC	CD	CE	CH	CT	CW	CX	KK	XC
16	16	15	5.5	12	6	23	20	2.3			M6×1.0	85
20	20	16	6.6	32	8	48	32	3.2	67	51	M8×1.25	100
25	22	16	6.6	32	8	48	32	3.2	67	51	M10×1.25	109
32	22	18	6.6	36	10	52	36	4	67	51	M10×1.25	114
40	30	20	6.6	40	12	56	40	4	71	55	M12×1.25	118

MCMA Installation of sensor switch $\phi 20 \sim \phi 40$

MINIATURE CYLINDERS



Sensor switch: RCA
 Sensor switch band: BA**

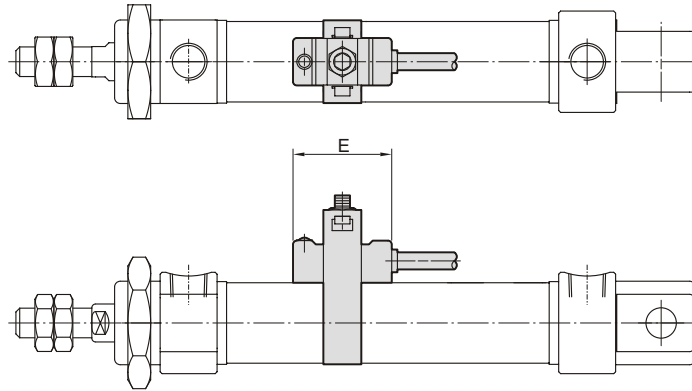
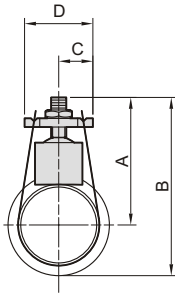

Code Tube I.D.	A	B	C	D	E
20	33	46.5	9	18	26
25	35.5	50.5	9	18	26
32	39	57	9	18	26
40	43	65.5	9	18	26

Sensor switch: RCA
 Sensor switch band: BGS**

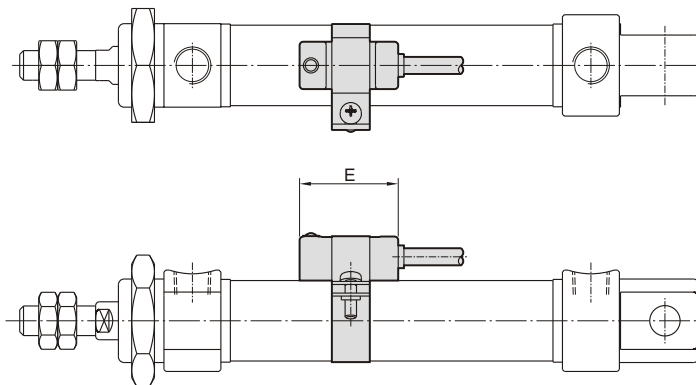
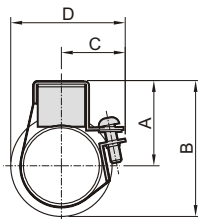

Code Tube I.D.	A	B	C	D	E
20	25	38.5	18	30.5	26
25	25.5	40.5	18.5	31.5	26
32	29	47	22	39	26
40	33	55.5	26	47	26

MCMA Installation of sensor switch $\phi 16 \sim \phi 40$

MINIATURE CYLINDERS



Sensor switch: RCM
 Sensor switch band: BM**

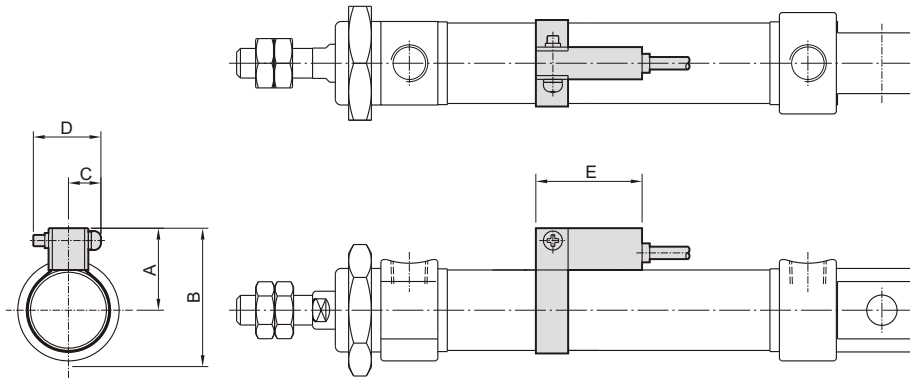

Code Tube I.D.	A	B	C	D	E
16	20	30	10	16	28
20	22	36	10	16	28
25	25	40	10	16	28
32	28	46	10	16	28
40	32	55	10	16	28

Sensor switch: RCS
 Sensor switch band: BJ 16

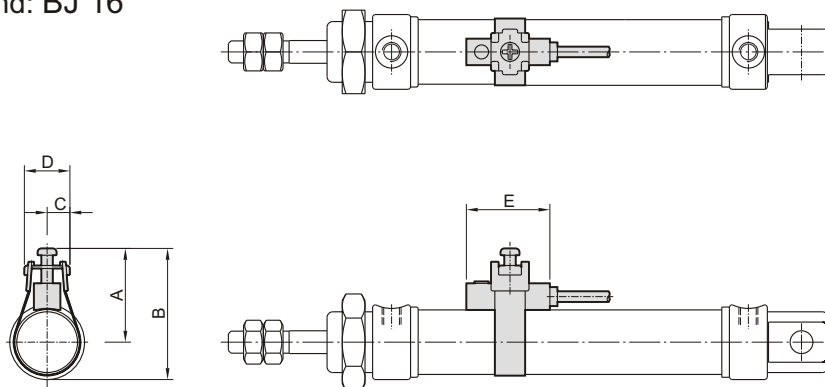

Code Tube I.D.	A	B	C	D	E
16	23.4	33.3	6	12	22

MCMA Dimensions / Single acting $\phi 16 \sim \phi 32$

MINIATURE CYLINDERS



15

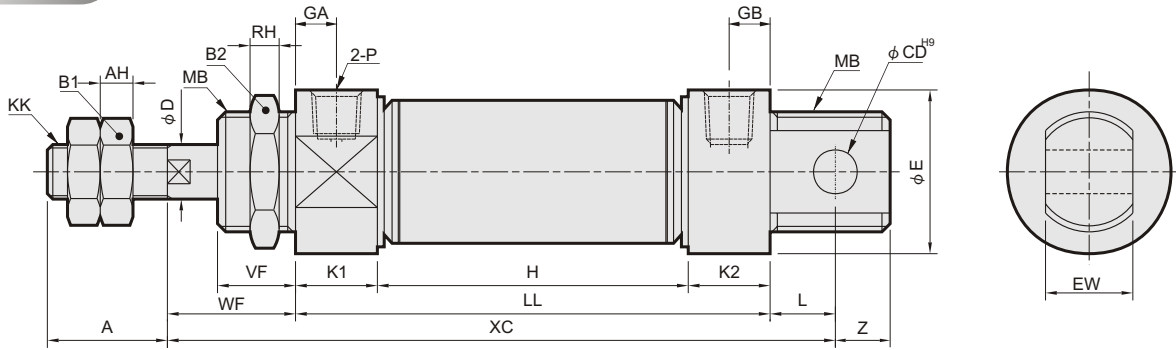

Code Tube I.D.	A	AH	B1	B2	CD	D	E	EW	GA	GB	KK	K1	K2	L	MB	P	RH	VF	WF	YP	Z
16	16	5	10	22	6	6	20	12 ^{-0.05/-0.4}	5	5	M6×1.0	10	10	9	M16×1.5	M5×0.8	6	12	22	5	7
20	20	5	13	30	8	10	27	16 ^{-0.05/-0.4}	7.5	7.5	M8×1.25	15	15	12	M22×1.5	PT 1/8	6	12	18	7.5	9
25	22	6	17	30	8	10	30	16 ^{-0.05/-0.4}	7.5	7.5	M10×1.25	15	15	12	M22×1.5	PT 1/8	6	15	27	7.5	9
32	22	6	17	32	10	12	45	16 ^{-0.05/-0.4}	7.5	10.5	M10×1.25	15	18	14	M24×2.0	PT 1/8	8	18	30	7.5	10

Code Stroke I.D.	H							LL							XC						
	15	25	50	75	100	125	150	15	25	50	75	100	125	150	15	25	50	75	100	125	150
16	64	74	114	154	194	/	/	84	94	134	174	214	/	/	115	125	165	205	245	/	/
20	80	90	140	190	240	290	340	110	120	170	220	270	320	370	140	150	200	250	300	350	400
25	80	90	140	190	240	290	340	110	120	170	220	270	320	370	149	159	209	259	309	359	409
32	77	87	137	187	237	287	337	110	120	170	220	270	320	370	154	164	214	264	314	364	414

21

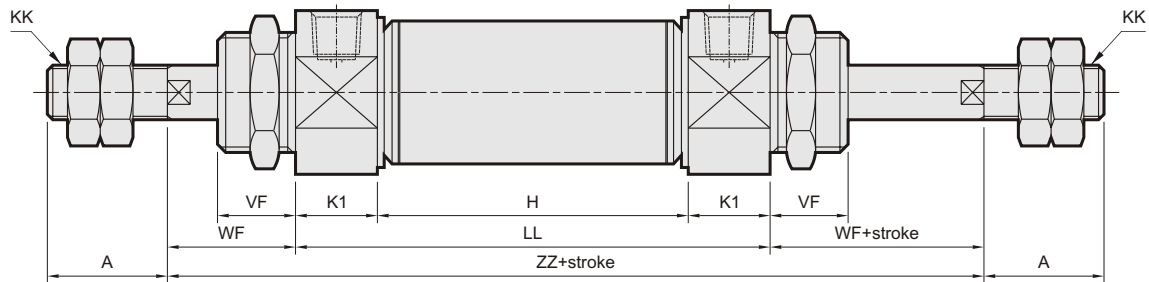

Code Stroke I.D.	H							LL							ZZ						
	15	25	50	75	100	125	150	15	25	50	75	100	125	150	15	25	50	75	100	125	150
16	64	74	114	154	194	/	/	84	94	134	174	214	/	/	125	135	175	215	255	/	/
20	80	90	140	190	240	290	340	110	120	170	220	270	320	370	146	156	206	256	306	356	406
25	80	90	140	190	240	290	340	110	120	170	220	270	320	370	164	174	224	274	324	374	424
32	77	87	137	187	237	287	337	107	117	167	217	267	317	367	167	177	227	277	327	377	427

LB

MCMA- $\phi 16$

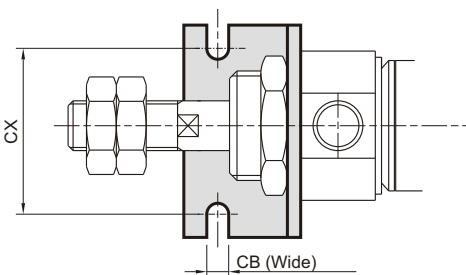

MCMA- $\phi 20 \sim \phi 32$

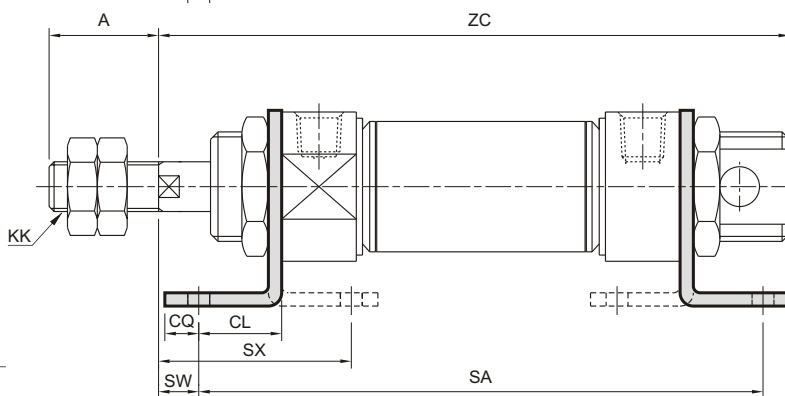
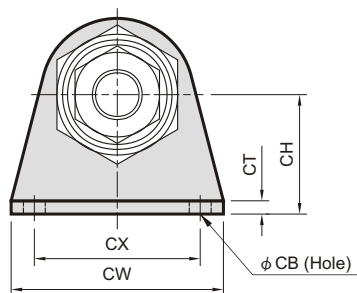

Code Tube I.D.	A	CB	CH	CL	CQ	CT	CW	CX	KK	SW	SX
16	16	5.5	20	13	6	3.2	44	32	M6×1.0	9	31.8
20	20	6.6	25	15	8	3.2	54	40	M8×1.25	3	29.8
25	22	6.6	25	15	8	3.2	54	40	M10×1.25	12	38.8
32	22	6.6	32	25	8	4	59	45	M10×1.25	5	51

Code Stroke I.D.	SA							ZC						
	15	25	50	75	100	125	150	15	25	50	75	100	125	150
16	110	120	160	200	240	/	/	121	131	171	211	251	/	/
20	140	150	200	250	300	350	400	146	156	206	256	306	356	406
25	140	150	200	250	300	350	400	155	165	215	265	315	365	415
32	160	170	220	270	320	370	420	162	172	222	272	322	372	422

MCMA Mounting accessories / Single acting $\phi 16 \sim \phi 32$

MINIATURE CYLINDERS



FA(FB)

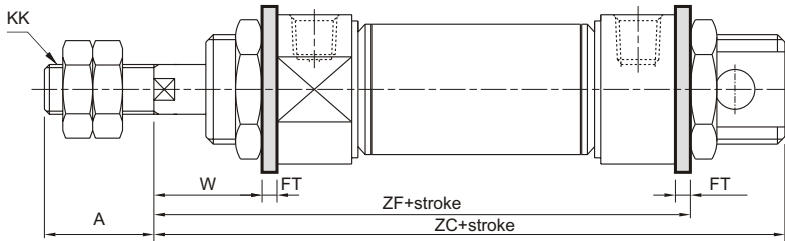

Code Tube I.D.	A	FB	FE	FF	FP	FR	FT	KK	W
16	16	5.5	26	52	40		3.2	M6×1.0	18.8
20	20	6.6	38	64	50		4.5	M8×1.25	13.5
25	22	6.6	38	64	50		4.5	M10×1.25	22.5
32	22	6.6	47	72	58	33	4.5	M10×1.25	25.5

Code Stroke I.D.	ZC						ZF							
	15	25	50	75	100	125	150	15	25	50	75	100	125	150
16	121	131	171	211	251			109.2	119.2	159.2	199.2	239.2		
20	146	156	206	256	306	356	406	132.5	142.5	192.5	242.5	292.5	342.5	392.5
25	155	165	215	265	315	365	415	141.5	151.5	201.5	251.5	301.5	351.5	401.5
32	162	172	222	272	322	372	422	144.5	154.5	204.5	254.5	304.5	354.5	404.5

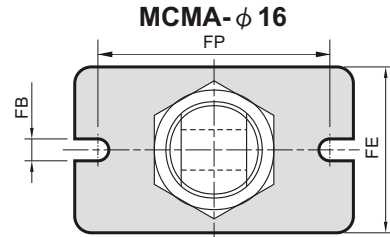

MCMA- $\phi 20, \phi 25$

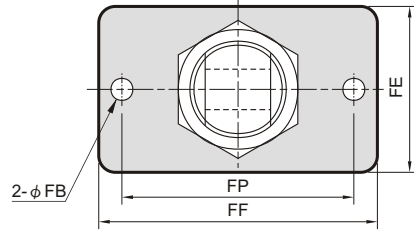

MCMA- $\phi 32$

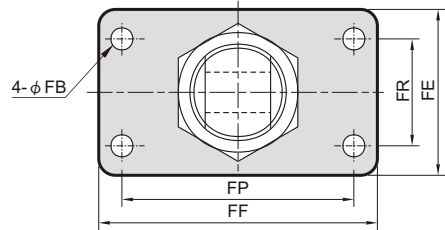

SDB

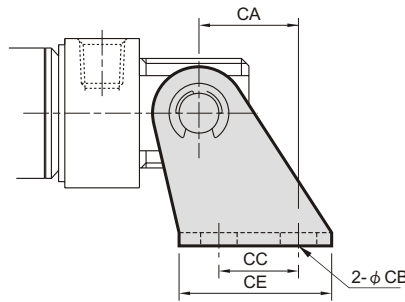

MCMA- $\phi 16$

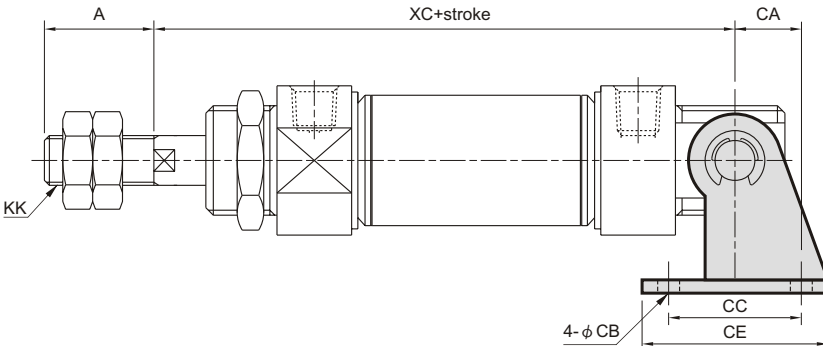
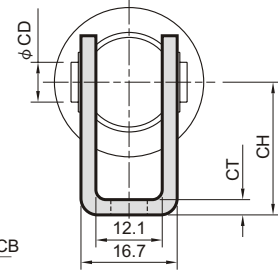

MCMA- $\phi 20 \sim \phi 32$

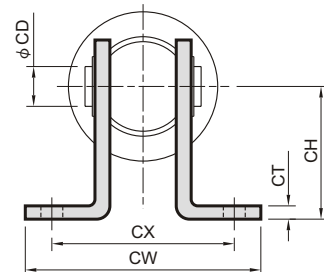

Code Tube I.D.	A	CA	CB	CC	CD	CE	CH	CT	CX	CW	KK
16	16	15	5.5	12	6	23	20	2.3		16.7	M6×1.0
20	20	16	6.6	32	8	48	32	3.2	51	67	M8×1.25
25	22	16	6.6	32	8	48	32	3.2	51	67	M10×1.25
32	22	18	6.6	36	10	52	36	4	51	67	M10×1.25

Code Stroke I.D.	XC						
	15	25	50	75	100	125	150
16	107	117	157	197	257		
20	139	149	199	249	299	349	399
25	141	151	172	222	272	322	372
32	142	152	173	223	273	323	373