

MCMBR* series

MINIATURE CYLINDERS

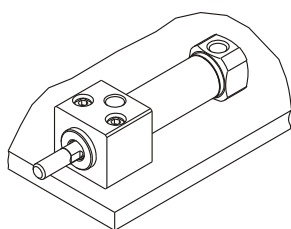

Mounting:



A: Bottom mounting

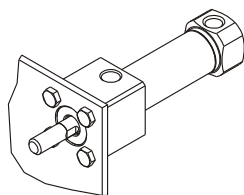

B: Front mounting

Order example:

MCMBRA-11-25-100-BSP

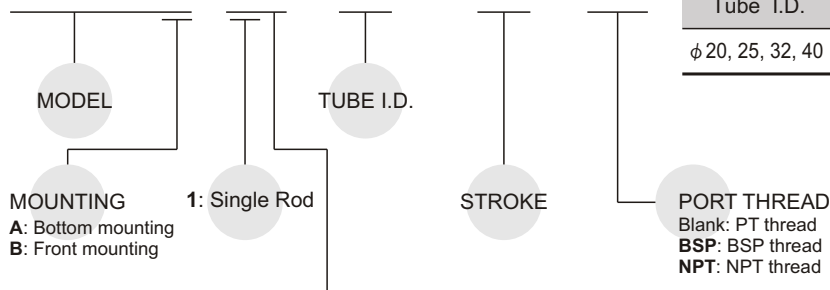

STYLE:

Code	Symbol	Description
1 1		Double acting / Male thread

Features:

■ Space saving configuration:

Because it is a directly mounted style without using brackets, its overall length is shorter, and its installation pitch can be made smaller. Thus, the space that is required for installation has been dramatically reduced.

■ Improved installation accuracy and strength.

■ Two styles of installation:

Two styles of installations are available and can be selected according to the purpose: the bottom mounting style or the front mounting style.

■ Standard with magnet.

Model	MCMBRA, MCMBRB			
Tube I.D. (mm)	φ 20	φ 25	φ 32	φ 40
Port size	PT 1/8			PT 1/4
Medium	Air			
Max operating pressure	9.9 kgf/cm ²			
Min operating pressure	0.5 kgf/cm ²			
Proof pressure	15 kgf/cm ²			
Ambient temperature	-5~+60°C (No freezing)			
Lubrication	Not required			
Available speed range	50~500mm/sec			
Cushion	with rubber cushion pad			
Sensor switch	RCA, RCM			
Sensor switch band	BA20	BA25	BA32	BA40
	BGS20	BGS25	BGS32	BGS40
	BM20	BM25	BM32	BM40

● Sensor switch band BM** only for RCM.

Table for standard stroke

Tube I.D.	Stroke (mm)
φ 20, 25, 32, 40	25, 50, 75, 100, 125, 150, 200, 250, 300

Double acting

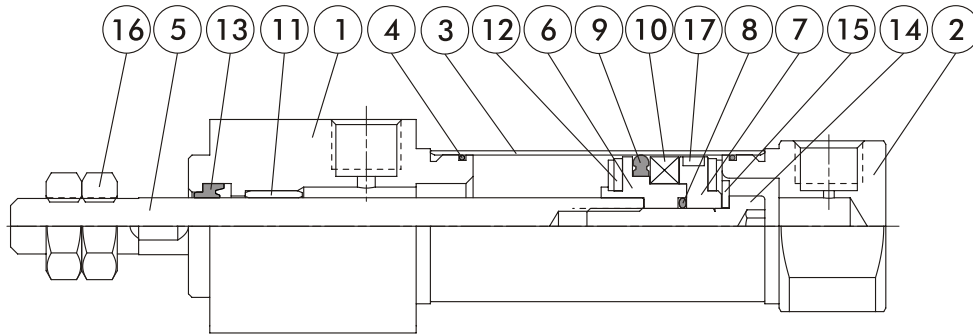

Material

No.	Part name	Material	Note
1	Rod cover	Aluminum alloy	
2	Head cover	Aluminum alloy	
3	Tube	Stainless steel	
4	Cover ring	NBR	
5	Piston rod	Carbon steel	
6	Piston-R	Aluminum alloy	
7	Piston-H	Aluminum alloy	
8	Piston gasket	NBR	
9	Piston packing	NBR	
10	Magnet ring	Magnet material	
11	Rod bush	Copper	
12	Cushion gasket	NBR	
13	Rod packing	NBR	
14	Piston bolt	SCM	
15	Washer	Rolled steel	
16	Rod front nut	Rolled steel	
17	Wear ring	Teflon	

MCMBR* Dimensions / Double acting $\phi 20 \sim \phi 40$

MINIATURE CYLINDERS



MCMBRA

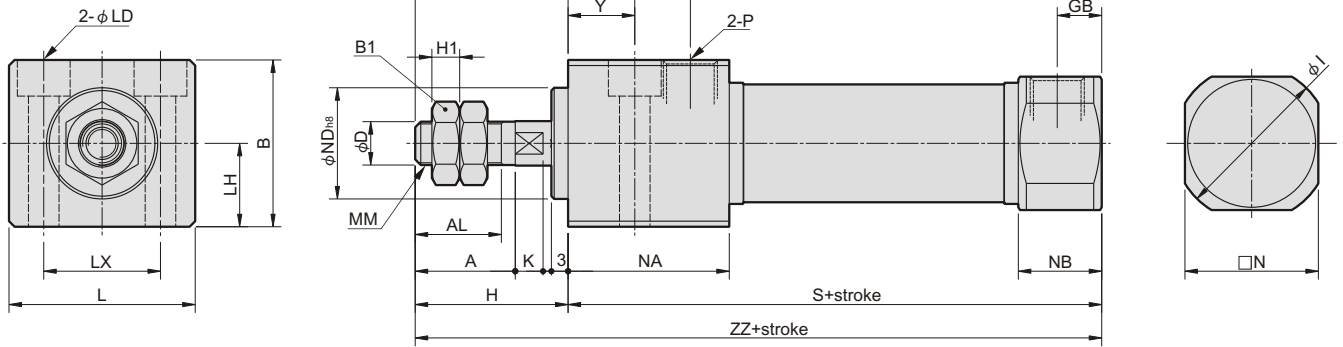

(mm)

Code Tube I.D.	A	AL	B	B1	D	GA	GB	H	H1	I	K	L	LD	LH	LX	MM	N	NA	NB	ND
20	18	15.5	30	13	8	22	8	27	5	28	5	33.5	$\phi 5.5$ thru, $\phi 9.5 \times 6.5$ depth	15	21	M8 \times 1.25	24	29	15	20 ⁰ _{-0.033}
25	22	19.5	36	17	10	22	8	31	6	33.5	5.5	39	$\phi 6.6$ thru, $\phi 11 \times 7.5$ depth	18	25	M10 \times 1.25	30	29	15	26 ⁰ _{-0.033}
32	22	19.5	42	17	12	22	8	31	6	37.5	5.5	47	$\phi 9$ thru, $\phi 14 \times 10$ depth	21	30	M10 \times 1.25	34.5	29	15	26 ⁰ _{-0.033}
40	24	21	52	22	14	27	11	34	8	46.5	7	58.5	$\phi 11$ thru, $\phi 17.5 \times 12.5$ depth	26	38	M14 \times 1.5	42.5	37.5	21.5	32 ⁰ _{-0.039}

Code Tube I.D.	P	S	X	Y	ZZ
20	PT 1/8	76	39	12	103
25	PT 1/8	76	43	12	107
32	PT 1/8	78	43	12	109
40	PT 1/4	104	49	15	138

MCMBRB

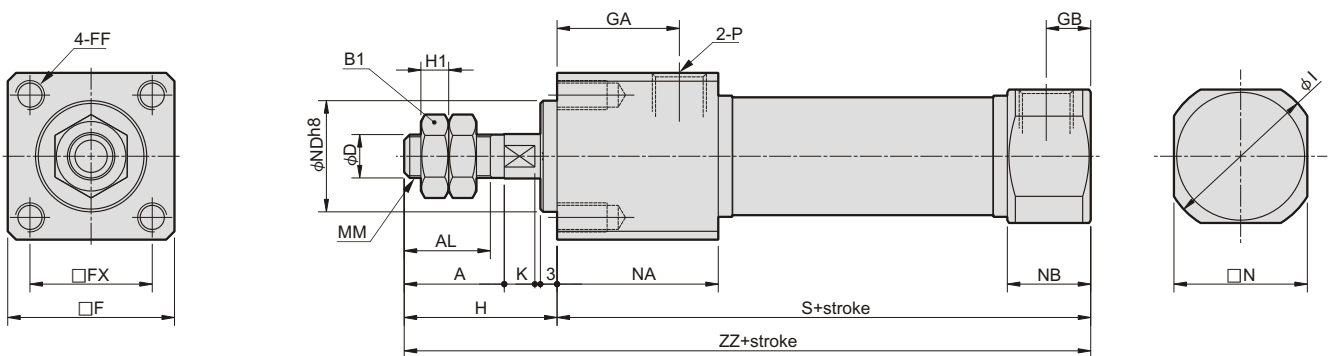

(mm)

Code Tube I.D.	A	AL	B1	D	F	FF	FX	GA	GB	H	H1	I	K	MM	N	NA	NB	ND	P	S	ZZ
20	18	15.5	13	8	30	M5 \times 0.8 \times 9 depth	22	22	8	27	5	28	5	M8 \times 1.25	24	29	15	20 ⁰ _{-0.033}	PT 1/8	76	103
25	22	19.5	17	10	36	M6 \times 1.0 \times 11 depth	26	22	8	31	6	33.5	5.5	M10 \times 1.25	30	29	15	26 ⁰ _{-0.033}	PT 1/8	76	107
32	22	19.5	17	12	42	M6 \times 1.0 \times 11 depth	30	22	8	31	6	37.5	5.5	M10 \times 1.25	34.5	29	15	26 ⁰ _{-0.033}	PT 1/8	78	109
40	24	21	22	14	52	M8 \times 1.25 \times 14 depth	36	27	11	34	8	46.5	7	M14 \times 1.5	42.5	37.5	21.5	32 ⁰ _{-0.039}	PT 1/4	104	138

MCMBR* Installation of sensor switch $\phi 20 \sim \phi 40$

MINIATURE CYLINDERS



Sensor switch: RCA
Sensor switch band: BA**

Code Tube I.D.	A	B	C	D	E
20	34	49	8	16	26
25	37	55	8	16	26
32	40	62	8	16	26
40	44	71	8	16	26

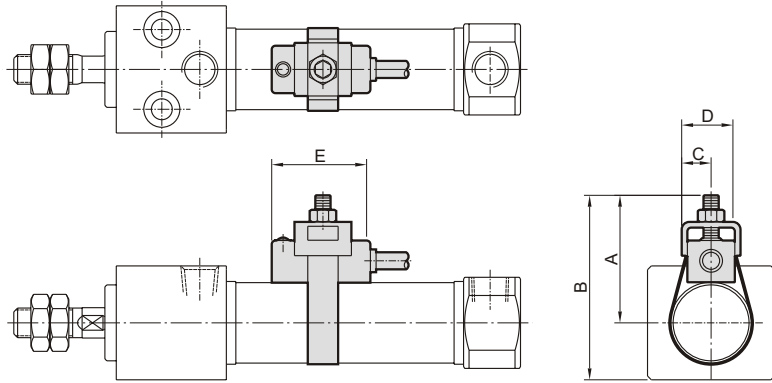

Sensor switch: RCA
Sensor switch band: BGS**

Code Tube I.D.	A	B	C	D	E
20	25	40	18	30	26
25	25.5	43.5	18.5	33.5	26
32	29	50.5	22	39.5	26
40	33	60	26	47.5	26

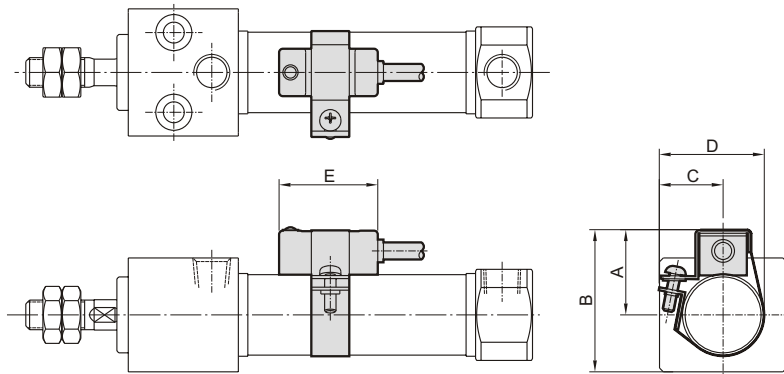

Sensor switch: RCM
Sensor switch band: BM**

Code Tube I.D.	A	B	C	D	E
20	22	37	10	16	28
25	25	43	10	16	28
32	28	50	10	16	28
40	32	59	10	16	28

